

# Service Manual

## Air Conditioner



**Indoor Unit**  
**CS-RE9HKE**  
**CS-RE12HKE**

**Outdoor Unit**  
**CU-RE9HKE**  
**CU-RE12HKE**

### **WARNING**

This service information is designed for experienced repair technicians only and is not designed for use by the general public. It does not contain warnings or cautions to advise non-technical individuals of potential dangers in attempting to service a product. Products powered by electricity should be serviced or repaired only by experienced professional technicians. Any attempt to service or repair the products dealt with in this service information by anyone else could result in serious injury or death.



## TABLE OF CONTENTS

<b>1. Safety Precautions</b> .....	<b>3</b>	<b>10. Installation Instruction</b> .....	<b>19</b>
<b>2. Specification</b> .....	<b>5</b>	10.1 Select the Best Location .....	19
2.1 CS-RE9HKE CU-RE9HKE.....	5	10.2 Indoor Unit.....	20
2.2 CS-RE12HKE CU-RE12HKE.....	7	10.3 Outdoor Unit.....	22
<b>3. Features</b> .....	<b>9</b>	<b>11. Service Mode</b> .....	<b>25</b>
<b>4. Location of Controls and Components</b> .....	<b>10</b>	11.1 Auto OFF/ON Button.....	25
4.1 Indoor Unit.....	10	11.2 Select Remote Control Transmission Code	25
4.2 Outdoor Unit.....	10	11.3 Operate and Display of Remote Control ...	26
4.3 Remote Control .....	10	<b>12. Operation Control</b> .....	<b>28</b>
<b>5. Dimensions</b> .....	<b>11</b>	12.1 Basic Function.....	28
5.1 Indoor Unit.....	11	12.2 Indoor Fan Motor Operation.....	29
5.2 Outdoor Unit.....	12	12.3 Outdoor Fan Motor Operation .....	29
<b>6. Refrigeration Cycle Diagram</b> .....	<b>13</b>	12.4 Airflow Direction .....	30
<b>7. Block Diagram</b> .....	<b>14</b>	<b>13. Protection control</b> .....	<b>32</b>
<b>8. Wiring Connection Diagram</b> .....	<b>15</b>	13.1 Protection Control For All Operations .....	32
<b>9. Printed Circuit Board</b> .....	<b>16</b>	13.2 Protection Control For Cooling and Soft Dry Operation.....	33
		13.3 Outdoor Air Temperature Control.....	34

<b>14. Troubleshooting Guide.....</b>	<b>36</b>
14.1 About Self Diagnosis .....	36
14.1 Display of Error Code.....	36
<b>15. Disassembly and Assembly Instructions .....</b>	<b>39</b>
<b>16. Exploded View and Replacement Pars List...42</b>	
16.1 Indoor Unit .....	42
16.2 Outdoor Unit .....	44

# 1. Safety Precautions







- Read the following “SAFETY PRECAUTIONS” carefully before perform any servicing.
- Electrical work must be installed or serviced by a licensed electrician. Be sure to use the correct rating of the power plug and main circuit for the model installed.
- The caution items stated here must be followed because these important contents are related to safety. The meaning of each indication used is as below. Incorrect installation or servicing due to ignoring of the instruction will cause harm or damage, and the seriousness is classified by the following indications.

 <b>WARNING</b>	This indication shows the possibility of causing death or serious injury
 <b>CAUTION</b>	This indication shows the possibility of causing injury or damage to properties.





- The items to be followed are classified by the symbols:

	This symbol denotes item that is PROHIBITED from doing.
---	---

- Carry out test run to confirm that no abnormality occurs after the servicing. Then, explain to user the operation, care and maintenance as stated in instructions. Please remind the customer to keep the operating instructions for future reference.

 <b>WARNING</b>	
1. Engage dealer or specialist for installation. If installation done by the user is defective, it will cause water leakage, electrical shock or fire.	
2. Install according to this installation instructions strictly. If installation is defective, it will cause water leakage, electrical shock or fire.	
3. Use the attached accessories parts and specified parts for installation. Otherwise, it will cause the set to fall, water leakage, fire or electrical shock.	
4. Install at a strong and firm location which is able to withstand the set's weight. If the strength is not enough or installation is not properly done, the set will drop and cause injury.	
5. Do not install outdoor unit near handrail of veranda. When installing air-conditioner unit at veranda of high rise building, child may climb up to outdoor unit and cross over the handrail and causing accident.	
6. For electrical work, follow the local national wiring standard, regulation and this installation instruction. An independent circuit and single outlet must be used. If electrical circuit capacity is not enough or defect found in electrical work, it will cause electrical shock or fire.	
7. This equipment is strongly recommended to be installed with Earth Leakage Circuit Breaker (ELCB) or Residual Current Device (RCD). Otherwise, it may cause electrical shock and fire in case equipment breakdown or insulation breakdown.	
8. This equipment must be properly earthed. Earth line must not be connected to gas pipe, water pipe, earth of lightning rod and telephone. Otherwise, it may cause electrical shock in case equipment breakdown or insulation breakdown.	
9. Use the specified cable (1.5 mm <sup>2</sup> ) and connect tightly for indoor/outdoor connection. Connect tightly and clamp the cable so that no external force will be acted on the terminal. If connection or fixing is not perfect, it will cause heat-up or fire at the connection.	
10. Wire routing must be properly arranged so that control board cover is fixed properly. If control board cover is not fixed perfectly, it will cause fire or electrical shock.	
11. When carrying out piping connection, take care not to let air substances other than the specified refrigerant go into refrigeration cycle. Otherwise, it will cause lower capacity, abnormal high pressure in the refrigeration cycle, explosion and injury.	
12. Do not damage or use unspecified power supply cord. Otherwise, it will cause fire or electrical shock.	
13. Do not modify the length of the power supply cord or use extension cord, and do not share the single outlet with other electrical appliances. Otherwise, it will cause fire or electrical shock.	
14. <ul style="list-style-type: none"> <li>• For R410A models, when connecting the piping, do not use any existing (R22) pipes and flare nuts. Using such same may cause abnormally high pressure in the refrigeration cycle (piping), and possibly result in explosion and injury. Use only R410A materials.</li> <li>• Thickness of copper pipes used with R410A must be more than 0.8 mm. Never use copper pipes thinner than 0.8 mm.</li> <li>• It is desirable that the amount of residual oil is less than 40 mg/10 m.</li> </ul>	
15. During installation, before run the compressor, confirm the refrigeration pipes are fixed. Operation of compressor without fixing the piping, setting the 2 way valve and 3 way valve at open condition, a burst may occur and cause injury.	
16. During pump down operation, stop the compressor before remove the refrigeration piping. When remove piping while 2 way valve, 3 way valve at open condition, burst may occur and cause injury.	
17. After completion of installation, confirm there is no leakage of refrigerant gas. It may generate toxic gas when the refrigerant contacts with fire.	
18. Ventilate if there is refrigerant gas leakage during operation. It may cause toxic gas when the refrigerant contacts with fire.	

 CAUTION

1. Do not install the unit at place where leakage of flammable gas may occur. In case gas leaks and accumulates at surrounding of the unit, it may cause fire.	
2. Carry out drainage piping as mentioned in installation instructions. If drainage is not perfect, water may enter the room and damage the furniture.	
3. Tighten the flare nut with torque wrench according to specified method. If the flare nut is over-tightened, after a long period, the flare may break and cause refrigerant gas leakage.	
4. Do not touch outdoor unit air inlet and aluminums fin. It may cause injury.	
5. Select an installation location which is easy for maintenance.	
6. Power supply connection to the air conditioner. Connect the power supply cord of the air conditioner to the mains using one of the following methods. Power supply point should be in easily accessible place for power disconnection in case of emergency. In some countries, permanent connection of this air conditioner to the power supply is prohibited. 1) Power supply connection to the receptacle using a power plug. Use an approved 15/16A power plug with earth pin for the connection to the receptacle. 2) Power supply connection to a circuit breaker for the permanent connection. Use an approved 16A circuit breaker for the permanent connection. It must be a double pole switch with a minimum 3.5 mm contact gap.	
7. Do not release refrigerant. Do not release refrigerant during piping work for installation, re-installation and during repairing a refrigeration parts. Take care of the liquid refrigerant, it may cause frostbite.	
8. Installation work. It may need two people to carry out the installation work.	
9. Do not install this appliance in a laundry room or other location where water may drip from the ceiling, etc.	

## 2. Specification

### 2.1 CS-RE9HKE CU-RE9HKE

Item		Unit	Indoor Unit	Outdoor Unit	
COOLING	Capacity	kW	2.60(0.90~3.00)		
		BTU/h	8870(3070~1023)		
	EER	W/W	3.56(4.74~3.00)		
		BTU/hW	12.15(16.16~10.23)		
Noise Level	dB(A)	Hi: 42 Lo: 27 QLo: 25	Hi: 47		
	Power level dB	53	60		
HEATING	Capacity	kW	3.30(0.90~4.10)		
		BTU/h	11250(3070~13980)		
	EER	W/W	4.02(5.29~3.57)		
		BTU/hW	13.72(18.06~12.16)		
Noise Level	dB(A)	Hi: 42 Lo: 27 QLo: 26	Hi: 47		
	Power level dB	53	60		
Moisture Removal		l/h	1.5		
		(pt/h)	2.6		
Air Volume	Lo	m <sup>3</sup> /m (ft <sup>3</sup> /m)	9.00(250)	-	
	Me	m <sup>3</sup> /m (ft <sup>3</sup> /m)	9.13(322)	-	
	Hi	m <sup>3</sup> /m (ft <sup>3</sup> /m)	11.6 (409)	28.9 (1020)	
Refrigerant Control Device			-	Capillary Tube	
Refrigerant Oil (Charged)		cm <sup>3</sup>	-	RB68A or Freol Alpha68M	
Refrigerant (Charged) R410A		kg (oz)	-	0.78 (27.5)	
Dimension	Height	mm (inch)	280 (11-1/32)	540 (21-1/4)	
	Width	mm (inch)	799 (31-15/32)	780 (30-23/32)	
	Depth	mm (inch)	183 (7-13/64)	289 (11-3/8)	
Net Weight		kg (lbs)	8.5 (19)	28 (62)	
Pipe Diameter	Gas	mm (inch)	9.52 (3/8)		
	Liquid	mm (inch)	6.35 (1/4)		
Pipe Length		m (ft)	3 (9.8) - 15(49.2)		
Height Difference		m (ft)	5 (16.4)		
Additional Gas Amount		g/m (oz/ft)	20 (0.2)		
Refrigerant Charge Less		m (ft)	7.5 (24.6)		
Drain Hose	Inner diameter	mm	14	-	
	Length	mm	500	-	
Compressor	Type		-	Rotary	
	Motor Type		-	Induction (6-poles)	
	Rated Output	W	-	750	
Fan	Type		Cross-Flow Fan	Propeller Fan	
	Material		AS	PP	
	Motor Type		Induction (8-poles)	Induction (6-poles)	
	Input power	W	-	-	
	Output power	W	30	15	
	Fan Speed	Lo	rpm	830	-
		Me	rpm	1070	-
Hi		rpm	1360	750	
Heat Exchanger	Fin material		Aluminium (Pre Coated)	Aluminum ( Pre Coated)	
	Fin type		Slit Fin	Slit Fin	
	Row x stage x FPI		2 x 15 x 20	1 x 24 x 17	
	Size (W x H x L)	mm	610 x 315 x 25.4	709 x 504 x 18.2	
Air Filter Type	Material		P.P.HONEY COMB	-	
	Style		One-Touch	-	

1. Cooling capacities are based on indoor temperature of 27°C Dry Bulb (80.6°F Dry Bulb), 19°C Wet Bulb (66.2°F Wet Bulb) and outdoor air temperature of 35°C Dry Bulb (95.0°F Dry Bulb), 24°C Wet Bulb (75.2°F Wet Bulb).
2. Heating capacities are based on indoor temperature of 20°C Dry Bulb (80.6°F Dry Bulb) and outdoor air temperature of 7°C Dry Bulb (44.6°F Dry Bulb), 6°C Wet Bulb (42.8°F Wet Bulb).

Item	Unit	
Power Source (Phase, Voltage, Cycle)	φ	Single
	V	230
	Hz	50
Input Power	W	730(190~1000)
Starting Current	A	3.70
Running Current	A	3.50
Maximum Current	A	6.00
Power Factor	%	91
Power factor means total figure of compressor, indoor fan motor and outdoor fan motor.		
Power Cord	Number of core	3 (1.5mm)
	Length	m 1.9
Thermostat		Electronic Control
Protection Device		Electronic Control

**Note**

Specification is subject to change without prior notice for further improvement.

## 2.2 CS-RE12HKE CU-RE12HKE

Item		Unit	Indoor Unit	Outdoor Unit	
COOLING	Capacity	kW	3.50(0.90~3.90)		
		BTU/h	11940(3070~13300)		
	EER	W/W	3.47(5.29~3.25)		
		BTU/hW	11.82(18.06~11.08)		
	Noise Level	dB(A)	Hi: 42 Lo: 30 QLo: 28	Hi: 48	
Power level dB		Hi: 53 Lo: -	Hi: 61		
HEATING	Capacity	kW	4.25(0.90~5.10)		
		BTU/h	14490(3070~17390)		
	COP	W/W	3.79(6.00~3.49)		
		BTU/hW	12.94(20.47~11.91)		
	Noise Level	dB(A)	Hi: 42 Lo: 33 QLo: 32	Hi: 50	
Power level dB		Hi: 53 Lo: -	Hi: 63		
Moisture Removal		l/h	2.0		
		(pt/h)	3.5		
Air Volume	Lo	m <sup>3</sup> /m (ft <sup>3</sup> /m)	8.03(283)	-	
	Me	m <sup>3</sup> /m (ft <sup>3</sup> /m)	9.91(350)	-	
	Hi	m <sup>3</sup> /m (ft <sup>3</sup> /m)	11.7 (413)	30.5 (1076)	
Refrigerant Control Device			-	Capillary Tube	
Refrigerant Oil (Charged)		cm <sup>3</sup>	-	RB68A or Freol Alpha68M	
Refrigerant (Charged) R410A		kg (oz)	-	0.97 (34.2)	
Dimension	Height	mm (inch)	280 (11-1/32)	540 (21-1/4)	
	Width	mm (inch)	799 (31-15/32)	780(30-23/32)	
	Depth	mm (inch)	183 (7-13/64)	289 (11-3/8)	
Net Weight		kg (lbs)	8.5 (19)	30 (66)	
Pipe Diameter	Gas	mm (inch)	9.52 (3/8)		
	Liquid	mm (inch)	6.35 (1/4)		
Pipe Length		m (ft)	3 (9.8) - 15 (49.2)		
Height Difference		m (ft)	5 (16.4)		
Additional Gas Amount		g/m (oz/ft)	20 (0.2)		
Refrigerant Charge Less		m (ft)	7.5 (24.6)		
Drain Hose	Inner diameter	mm	14	-	
	Length	mm	500	-	
Compressor	Type		-	Rotary	
	Motor Type		-	Induction (6-poles)	
	Rated Output	W	-	900	
Fan	Type		Cross-Flow Fan	Propeller Fan	
	Material		AS	PP	
	Motor Type		Induction (8-poles)	Induction (6-poles)	
	Input power	W	-	-	
	Output power	W	30	25	
	Fan Speed	Lo (Cool)	rpm	940	-
		Me (Cool)	rpm	1160	-
Hi (Cool)		rpm	1370	870	
Heat Exchanger	Fin material		Aluminum (Pre Coated)	Aluminum (Pre Coated)	
	Fin type		Slit Fin	Slit Fin	
	Row x stage x FPI		2 x 15 x 20	2 x 20 x 17	
	Size (W x H x L)	mm	610 x 315 x 25.4	709 x 540 x 36.4	
Air Filter Type	Material		P.P.HONEY.COMP	-	
	Style		One-Touch	-	

1. Cooling capacities are based on indoor temperature of 27°C Dry Bulb (80.6°F Dry Bulb), 19°C Wet Bulb (66.2°F Wet Bulb) and outdoor air temperature of 35°C Dry Bulb (95.0°F Dry Bulb), 24°C Wet Bulb (75.2°F Wet Bulb).
2. Heating capacities are based on indoor temperature of 20°C Dry Bulb (80.6°F Dry Bulb) and outdoor air temperature of 7°C Dry Bulb (44.6°F Dry Bulb), 6°C Wet Bulb (42.8°F Wet Bulb).

Item	Unit	
Power Source (Phase, Voltage, Cycle)		Single
	V	230
	Hz	50
Input Power	W	1010(170~1200)
Starting Current	A	4.90
Running Current	A	4.70
Maximum Current	A	6.80
Power Factor	%	93
Power factor means total figure of compressor, indoor fan motor and outdoor fan motor.		
Power Cord	Number of core	3 (1.5mm)
	Length	m 1.9
Thermostat		Electronic Control
Protection Device		Electronic Control

**Note**

Specification is subject to change without prior notice for further improvement.



### 3. Features

- Inverter Technology
  - Wider output power range
  - Energy saving
  - Quick Cooling
  - More precise temperature control
- Long Installation Piping
  - CS/CU-RE9/12GKR, long piping up to 10 meters.
- Easy to use remote control
- Quality Improvement
  - Random auto restart after power failure for safety restart operation
  - Gas leakage protection
  - Prevent compressor reverse cycle
  - Inner protector to protect compressor
- Operation Improvement
  - Quiet mode to reduce the indoor unit operating sound
  - Powerful mode to reach the desired room temperature quickly
  - 12-hour timer
- Serviceability Improvement
  - Breakdown Self Diagnosis Function.

## 4. Location of Controls and Components

### 4.1 Indoor Unit

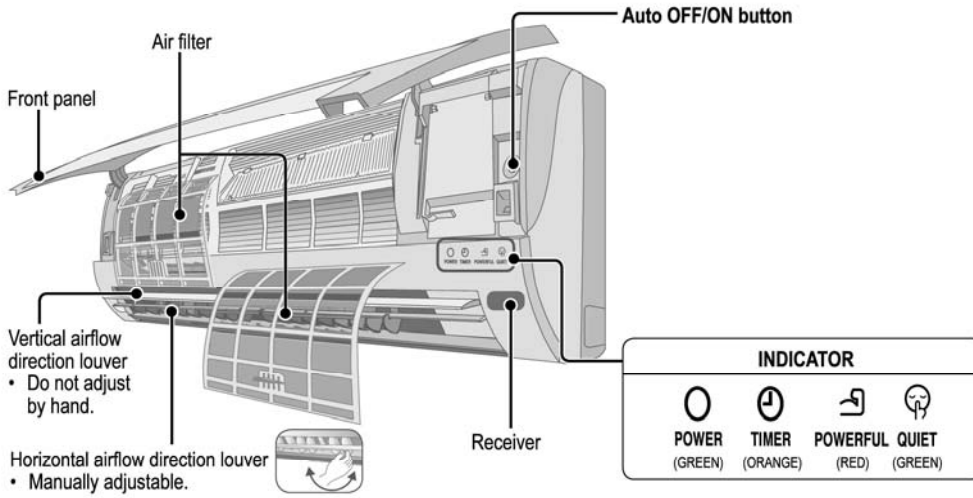

### 4.2 Outdoor Unit

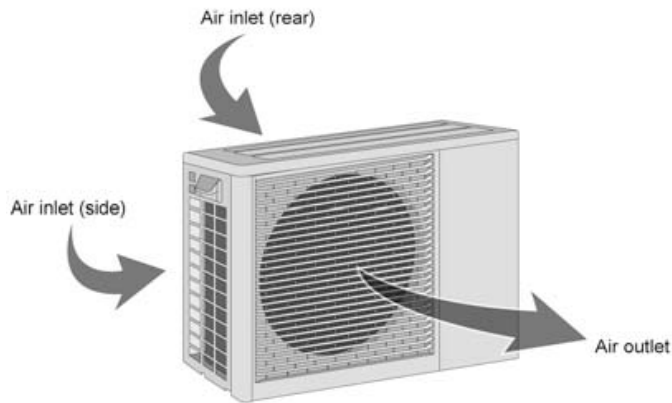

### 4.3 Remote Control

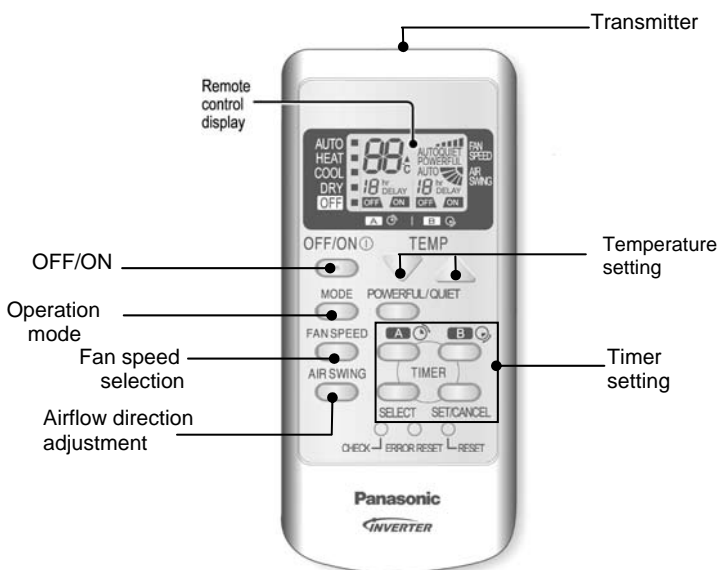

- For normal operation, the ERROR RESET button is not in use.
- Press RESET button to restore the remote control's default setting.

## 5. Dimensions

### 5.1 Indoor Unit

Unit : mm

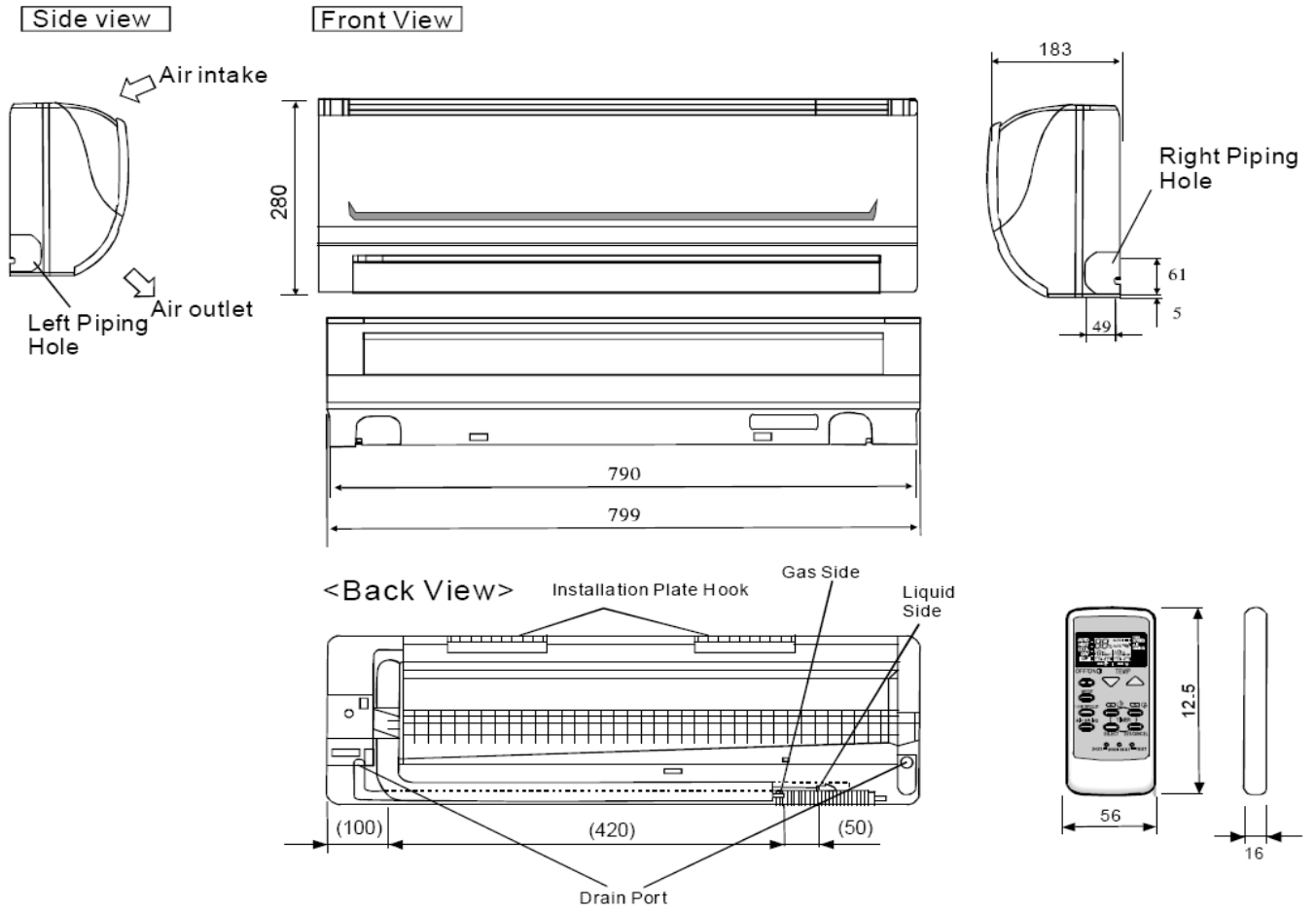

### Installation plate (Front View)

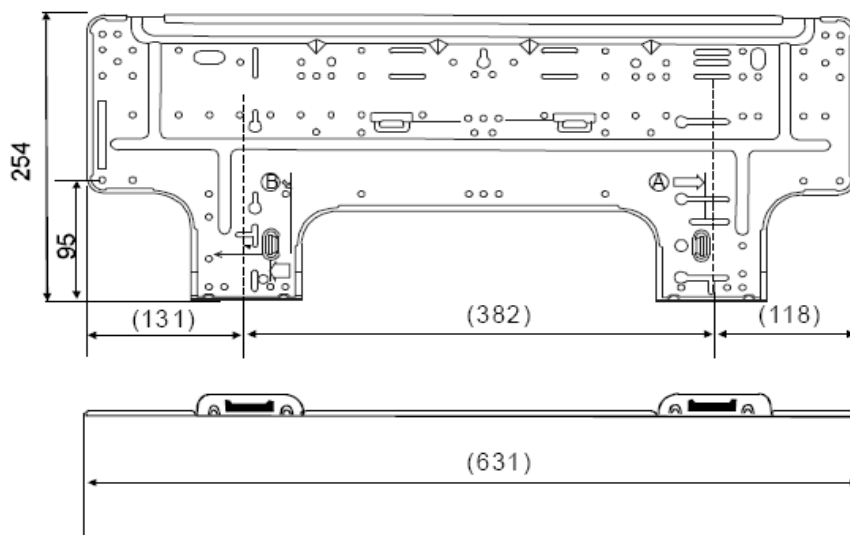

## 5.2 Outdoor Unit

Unit: mm

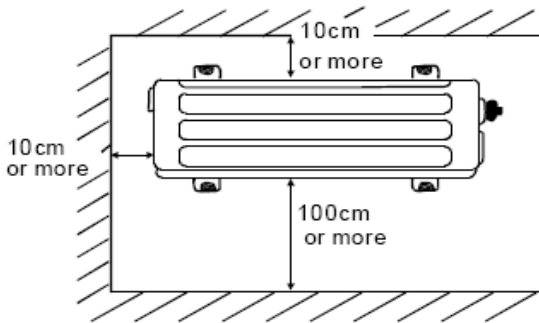

<Top View>

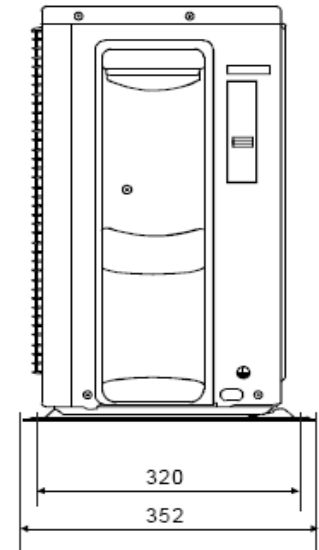
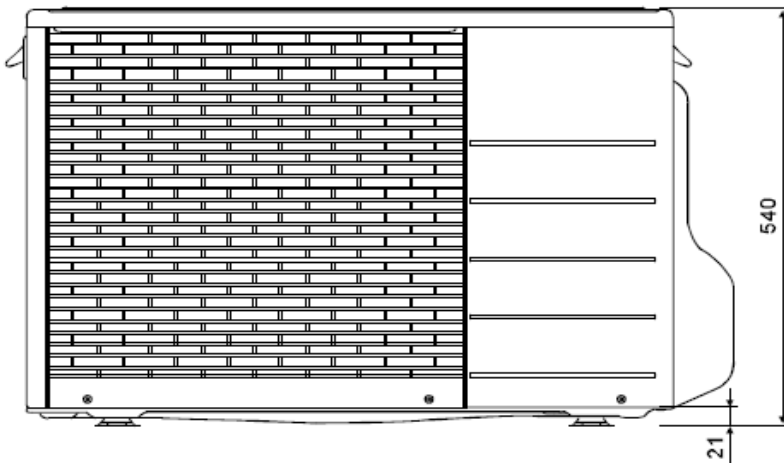
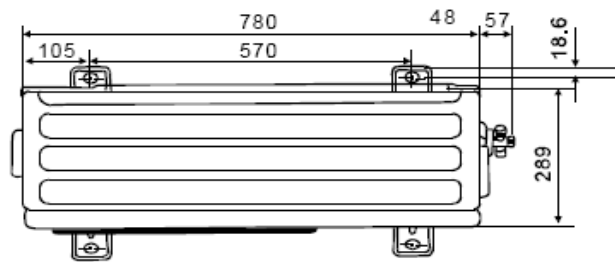

## 6. Refrigeration Cycle Diagram

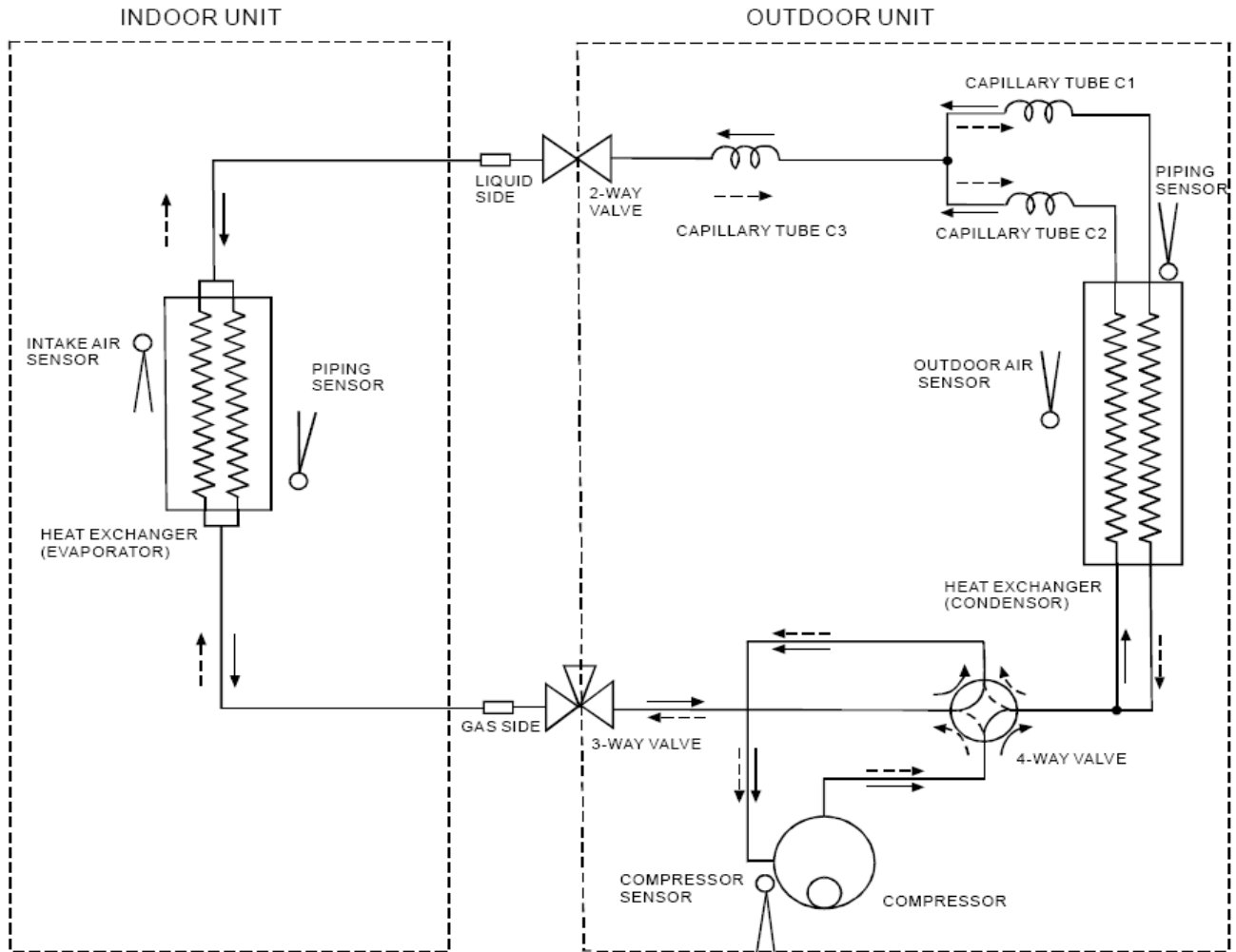

→ Cooling  
 - - - - - Heating

## 7. Block Diagram

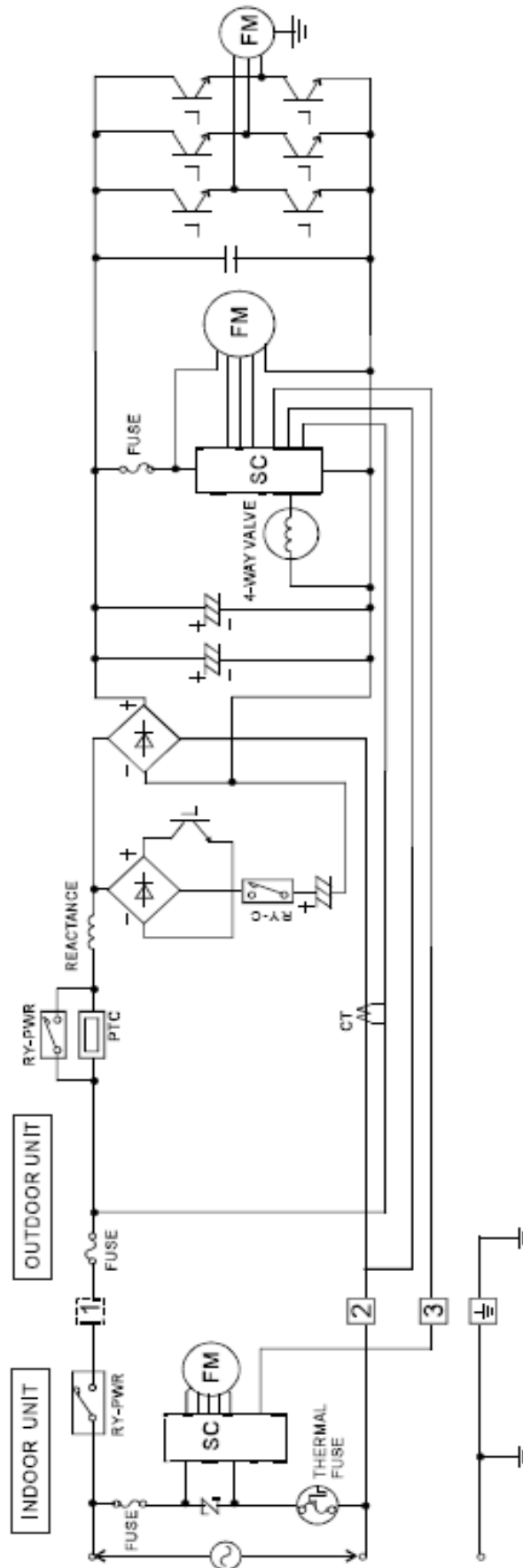

# 8. Wiring Diagram

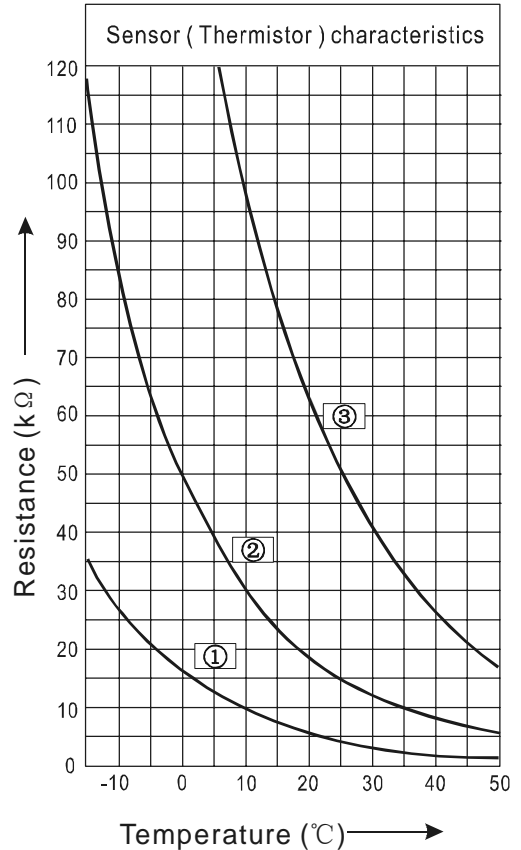
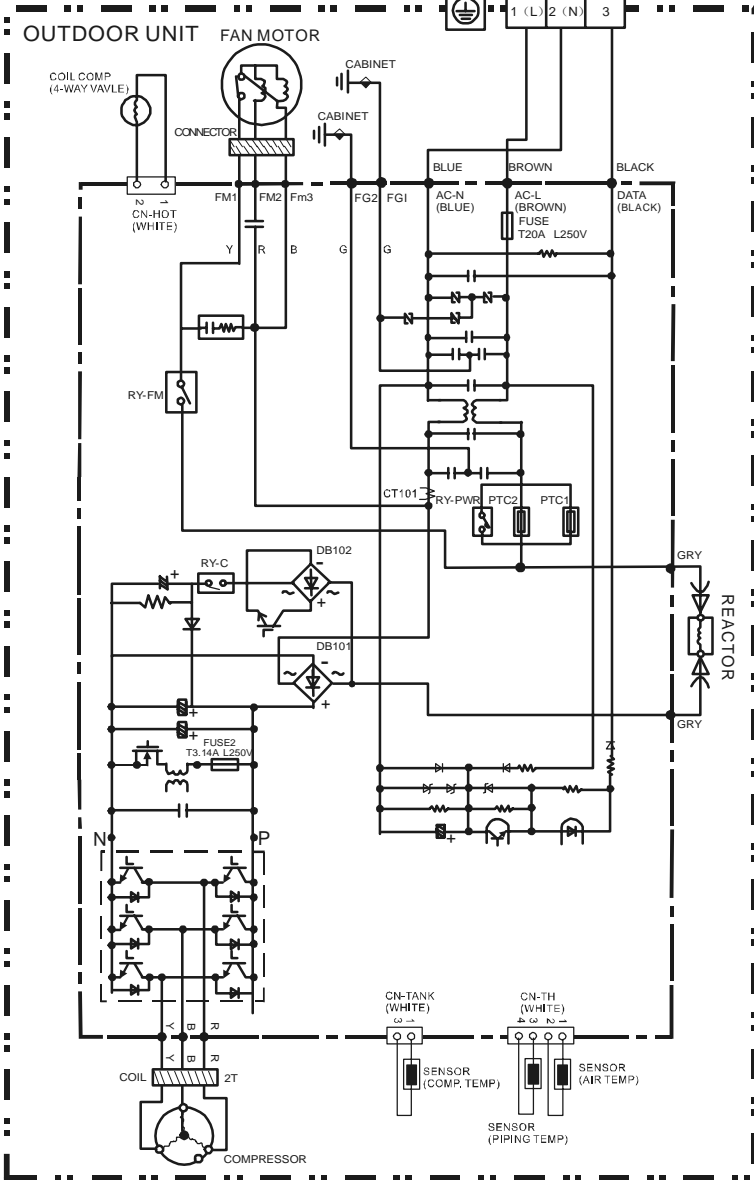
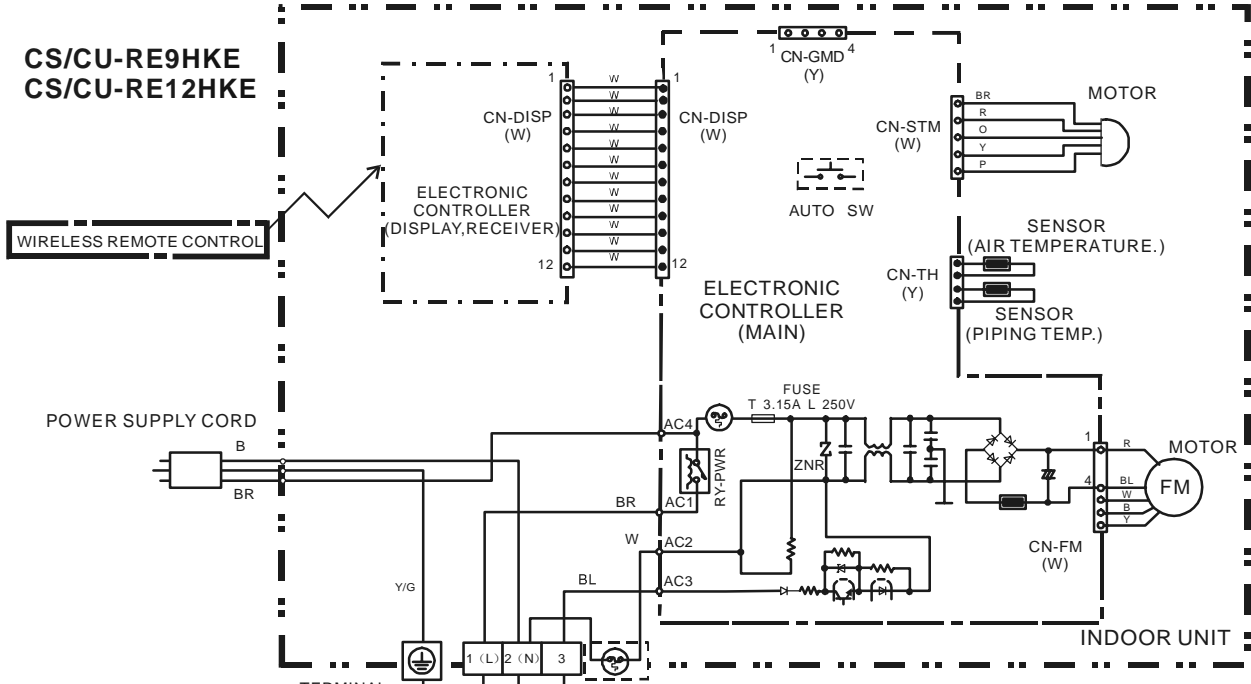

Remark:

- ①: Pipe Temp. Sensor
- ②: Outdoor air sensor
- ③: Discharge Temp. Sensor

### COMPRESSOR TERMINAL

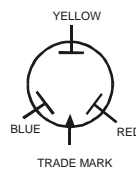

## 9. Printed Circuit Board

### 9.1 Indoor Unit

#### 9.1.1 Main Printed Circuit Board

TOP VIEW

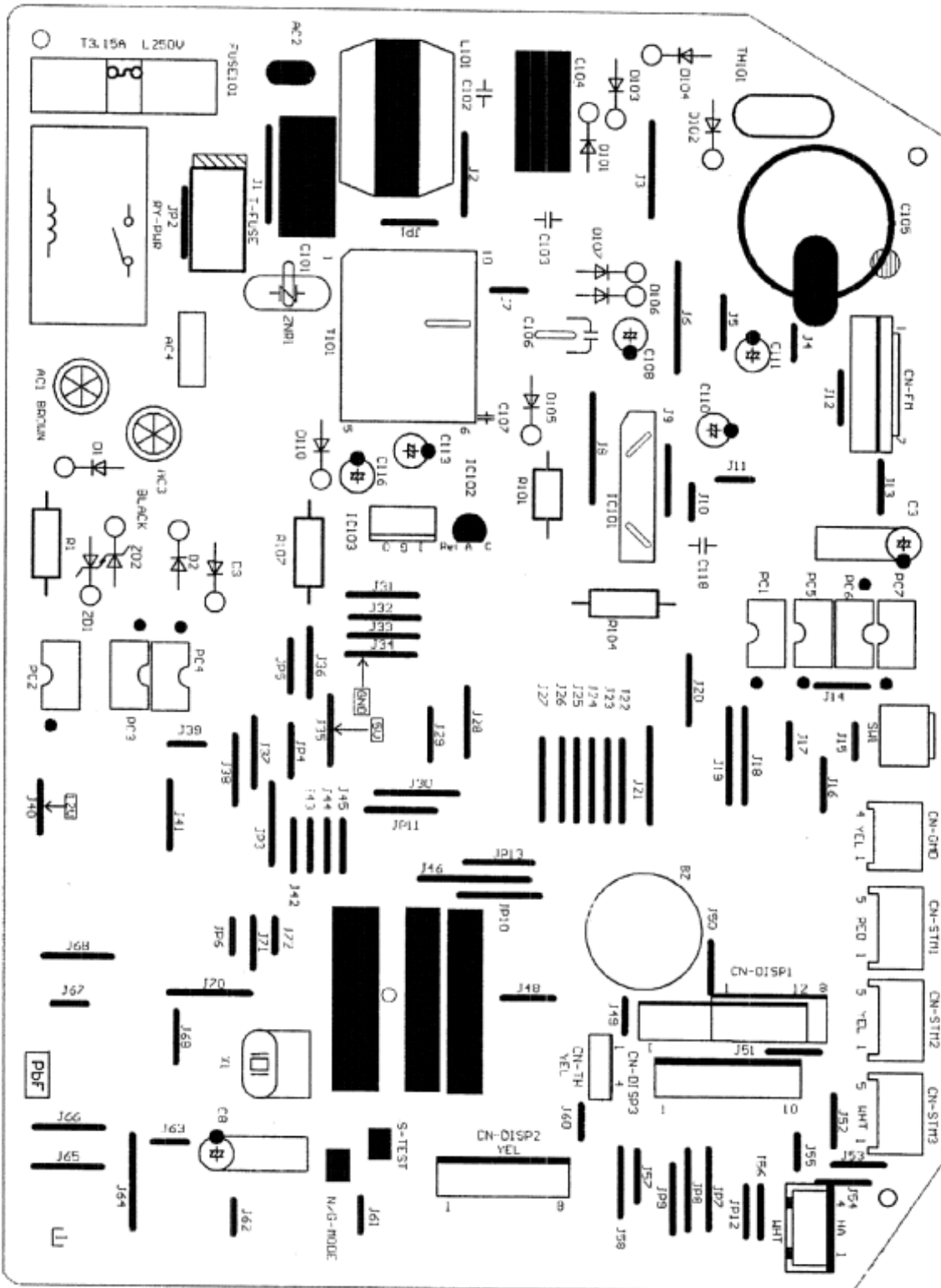



BOTTOM VIEW

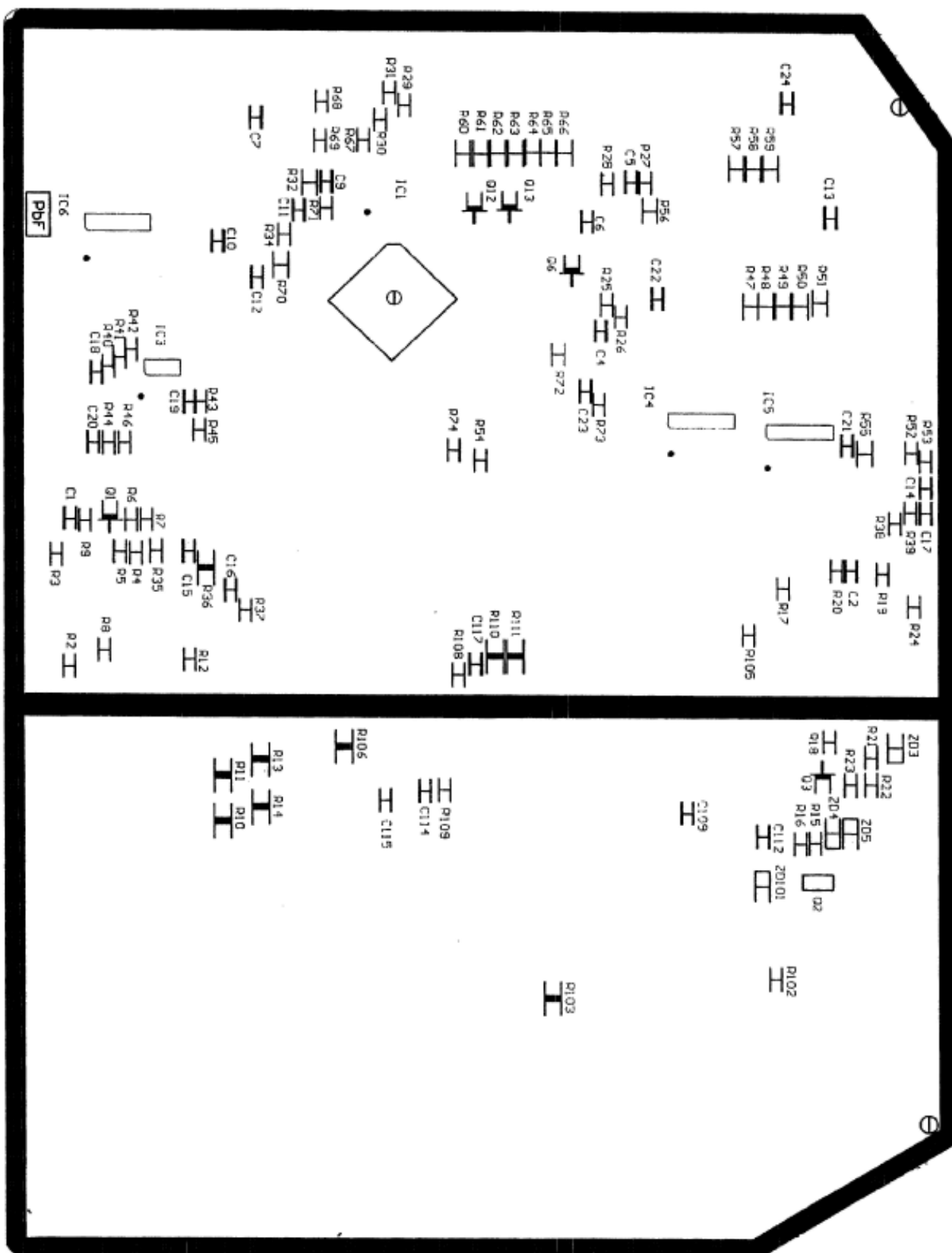

### 9.1.2 Indicator

TOP VIEW

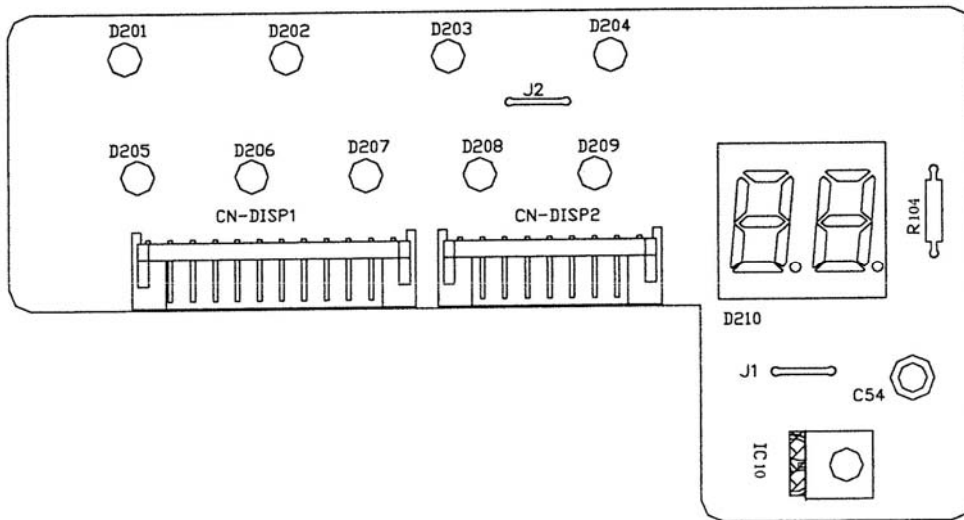

BOTTOM VIEW

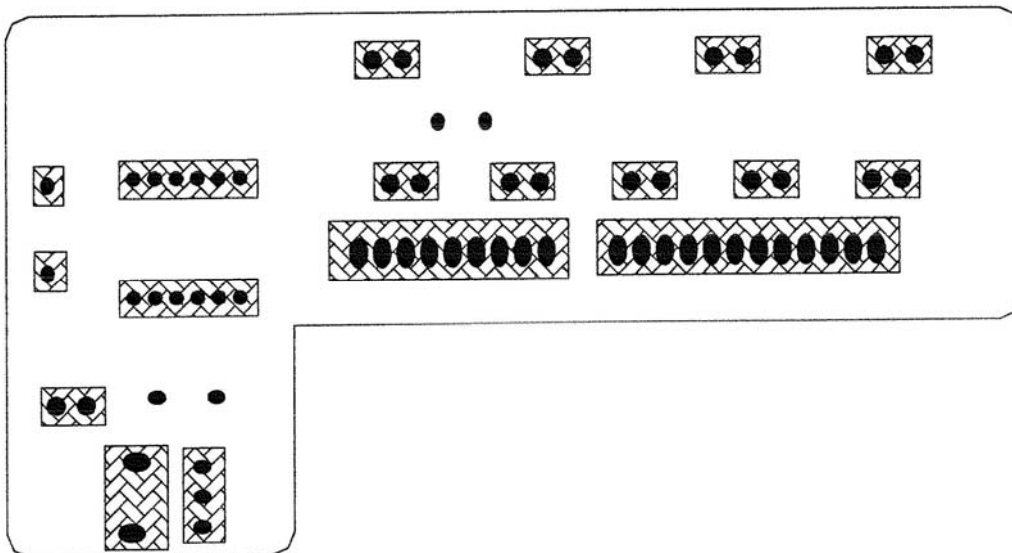

## 10. Installation Instruction

### 10.1 Select the Best Location

#### 10.1.1 Indoor Unit

- There should not be any heat source or steam near the unit.
- There should not be any obstacles blocking the air circulation.
- A place where air circulation in the room is good.
- A place where drainage can be easily done.
- A place where noise prevention is taken into consideration.
- Do not install the unit near the door way.
- Ensure the spaces indicated by arrows from the wall, ceiling, fence or other obstacles.
- Recommended installation height for indoor unit shall be at least 2.5m.

#### 10.1.2 Outdoor Unit

- If an awning is built over the unit to prevent direct sunlight or rain, be careful that heat radiation from the condenser is not obstructed.
- There should not be any animal or plant which could be affected by hot air discharged.
- Keep the spaces indicated by arrows from wall, ceiling, fence or other obstacles.
- Do not place any obstacles which may cause a short circuit of the discharged air.
- If piping length is over the rated length, additional refrigerant should be added as shown in the table below:

Model	Piping size		Rated Length (m)	Max Elevation (m)	Min Piping Length (m)	Max Piping Length (m)	Additional Refrigerant (g/m)
	Gas	Liquid					
RE9HKE	3/8"	1/4"	7.5	5	3	15	20
RE12HKE	3/8"	1/4"	7.5	5	3	15	20

Example: If the unit is installed at a 10m distance, the quantity of additional refrigerant should be 50 g.  
 ..... (10-7.5) m x 20g/m = 50 g

#### 11.1.3 Indoor/Outdoor Unit

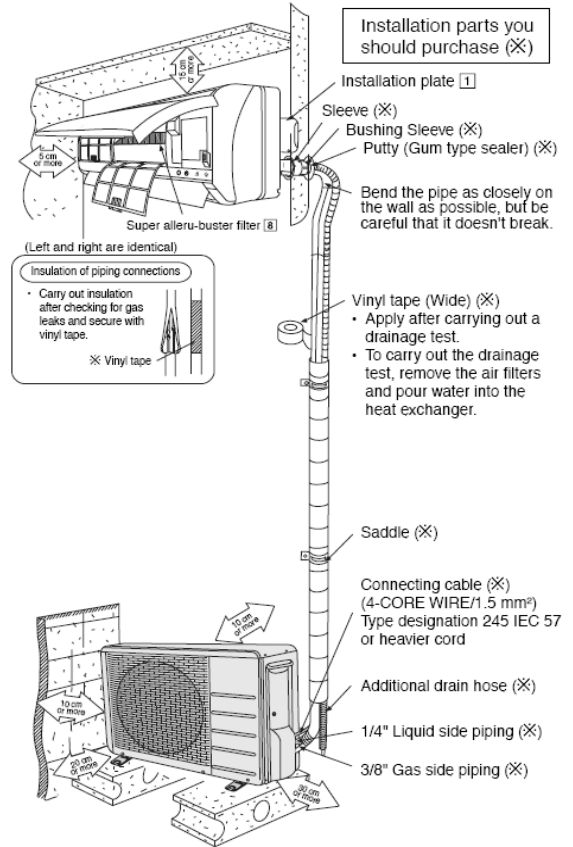
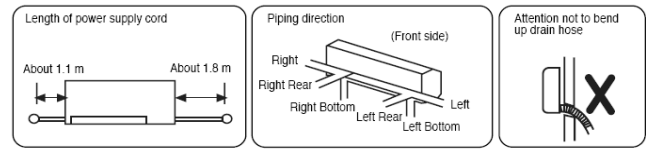

CU-RE9HKE, CU-RE12HKE

- This illustration is for explanation purposes only. The indoor unit will actually face a different way.

## 10.2 Indoor Unit

### 10.2.1 How to Fix Installation Plate

The mounting wall is strong and solid enough to prevent it from the vibration.

The centre of installation plate should be at more than 450 mm at right and left of the wall.

The distance from installation plate edge to ceiling should more than 75mm.

From installation plate left edge to unit's left side is 98mm.

From installation plate right edge to unit's right side is 112mm.

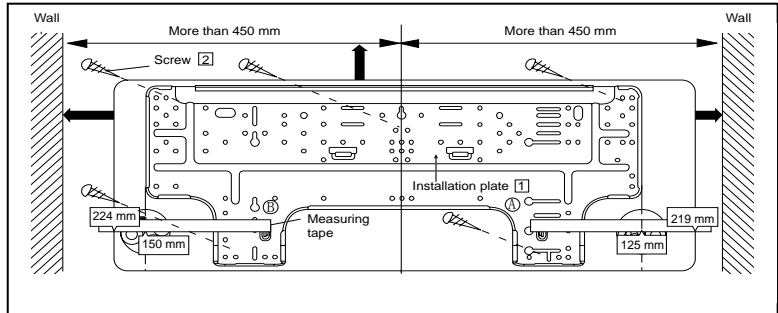

- Ⓑ : For left side piping, piping connection for gas should be about 45mm from this line.  
 : For left side piping, piping connection cable should be about 800mm from this line.

- 1 Mount the installation plate on the wall with 5 screws or more. (If mounting the unit on the wall, consider using anchor bolts.) Always mount the installation plate horizontally by aligning the marking-off line with the thread and using a level gauge.
- 2 Drill the piping plate hole with  $\varnothing 70$ mm hole-core drill.
  - 2.1 Line according to the left and right side edge of the installation plate. The meeting point of the extended line is the centre of the hole. Another method is by putting measuring tape at position as shown in the diagram above. The hole centre is obtained by measuring the distance namely 150mm and 125mm for left and right hole respectively.
  - 2.2 Drill the piping plate hole at either the right or left and the hole should be slightly slanted to the outdoor side.

### 10.2.2 To Drill a Hole in the Wall and Install a Sleeve of Piping

- 1 Insert the piping sleeve to the hole.
- 2 Fix the busing to the sleeve.
- 3 Cut the sleeve until it extrudes about 15mm from the wall

**Caution**

When the wall is hollow, please be sure to use the sleeve for tube ass'y to prevent dangers caused by mice biting the connecting cable.

- 4 Finish by sealing the sleeve with putty or caulking compound at the final stage.

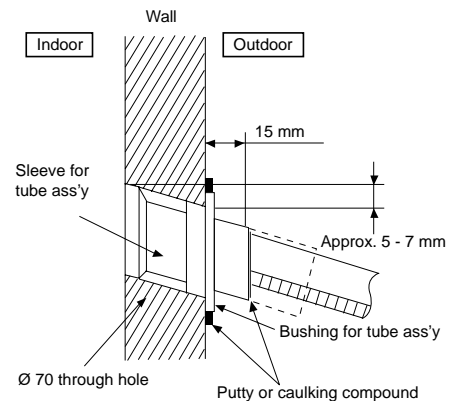

### 10.2.3 Indoor Unit Installation

1. FOR THE RIGHT REAR PIPING
- Pull out the Indoor piping
- Install the Indoor Unit
- Secure the Indoor Unit
- Insert the connecting cable

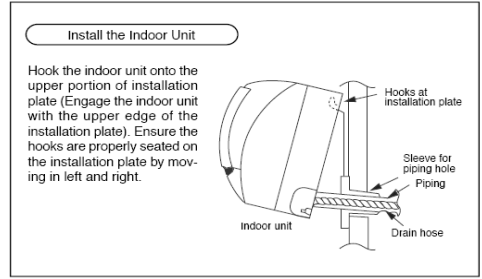
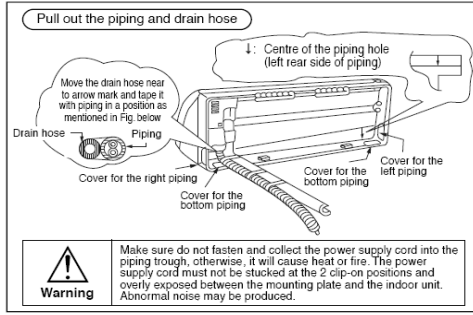

2. FOR THE RIGHT AND RIGHT BOTTOM PIPING
- Pull out the Indoor piping
- Install the Indoor Unit
- Insert the connecting cable
- Secure the Indoor Unit

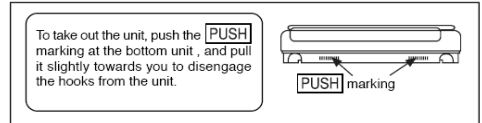
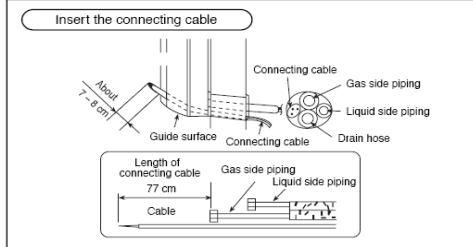
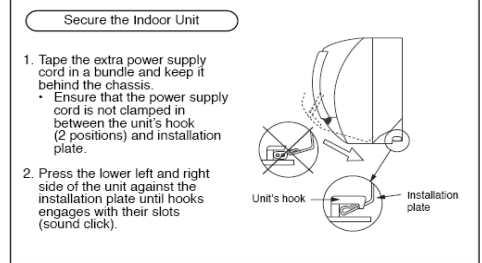
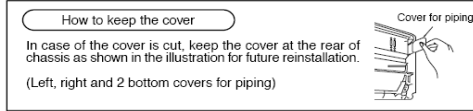





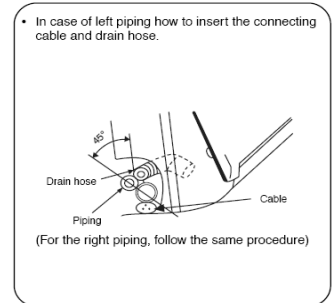
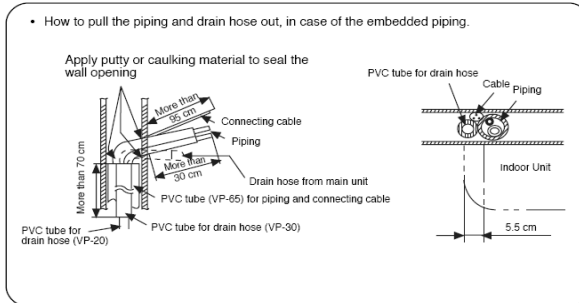
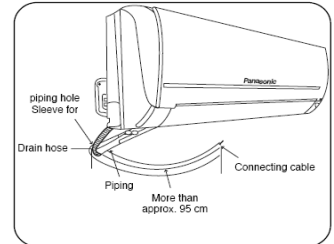
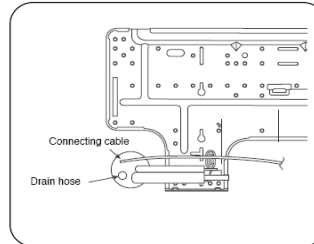
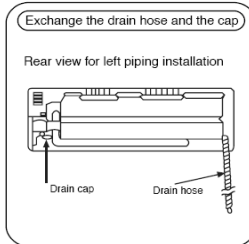

3. FOR THE EMBEDDED PIPING
- Replace the drain hose
- Bend the embedded piping
  - Use a spring bender or equivalent to bend the piping so that the piping is not crushed.
- Install the Indoor Unit
- Cut and flare the embedded piping
  - When determining the dimensions of the piping, slide the unit all the way to the left on the installation plate.
  - Refer to the section "Cutting and flaring the piping".
- Pull the connecting cable into Indoor Unit
  - The inside and outside connecting cable can be connected without removing the front grille.
- Connect the piping
  - Please refer to "Connecting the piping" column in outdoor unit section. (Below steps are done after connecting the outdoor piping and gas-leakage confirmation.)
- Insulate and finish the piping
  - Please refer to "Insulation of piping connections" column as mentioned in Indoor/Outdoor Unit Installation.
- Secure the Indoor Unit

(This can be used for left rear piping & left bottom piping also.)



### 10.2.4 Connect the Cable to the Indoor Unit

- 1 The inside and outside connecting cable can be connected without removing the front grille.
- 2 Connecting cable between indoor unit and outdoor unit shall be approved polychloroprene sheathed 4x 1.5mm<sup>2</sup> flexible cord, type designation 245 IEC 57 or heavier cord.
  - ◆ Ensure the color of wires of outdoor unit and the terminal numbers are the same to the indoor's respectively.
  - ◆ Earth lead wire shall be longer than the other lead wires as shown in the figure for the electrical safety in case of the slipping out of the cord from the anchorage.

Terminals on the indoor unit	1(L)	2(N)	3	
Colour of wires				
Terminals on the outdoor unit	1(L)	2(N)	3	

- ◆ Secure the cable onto the board with the holder (clammer).

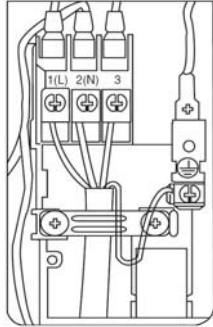

## 10.3 Outdoor Unit

### 10.3.1 Install the Outdoor Unit

- After selecting the best location, start installation according to indoor/outdoor unit installation diagram.
  - 1 Fix the unit on concrete or rigid frame firmly and horizontally by bolt nut (ø10mm).
  - 2 When installing at roof, please consider strong wind and earthquake. Please fasten the installation stand firmly with bolt or nails.

A	B	C	D
570	104	20	320

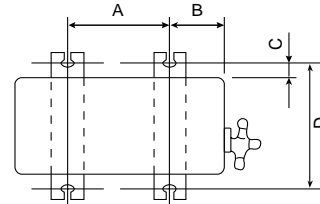

### 10.3.2 Connecting the Piping

#### 10.3.2.1 Connecting the piping to indoor unit

Please make flare after inserting flare nut (locate at joint portion, of tube assembly) onto the copper pipe. (In case of using long piping)

Connect the piping

- Align the center of piping and sufficiently tighten the flare nut with fingers.
- Further tighten the flare nut with torque wrench in specified torque as stated in the table.

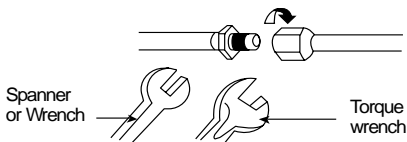

Piping size (Torque)	
Gas	Liquid
3/8" (42N•m)	1/4" (18N•m)
1/2" (55N•m)	1/4" (18N•m)

Do not over tighten, over tightening cause gas leakage

Connecting the piping to outdoor unit

Decide piping length and then cut by using pipe cutter. Remove burrs from cut edge. Make flare after inserting the flare nut (locate at valve) onto the copper pipe. Align center of piping to valves and then tighten with torque wrench to the specified torque as stated in the table.



### 10.3.2.2 Cutting and flaring the piping

- 1 Please cut using pipe cutter and then remove the burrs.
- 2 Remove the burrs by using reamer. If burrs are not removed, gas leakage may be caused. Turn the piping end down to avoid the metal powder entering the pipe.
- 3 Please make flare after inserting the flare nut onto the copper pipes.

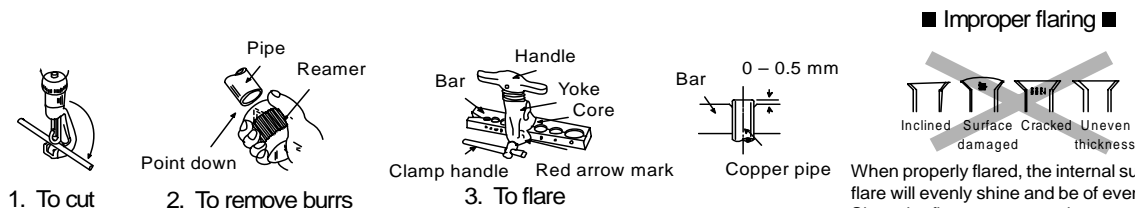

When properly flared, the internal surface of the flare will evenly shine and be of even thickness. Since the flare part comes into contact with the connections, carefully check the flare finish.

### 10.3.3 Evacuation of the equipment

When installing an air conditioner, be sure to evacuate the air inside the indoor unit and pipes in the following procedure.

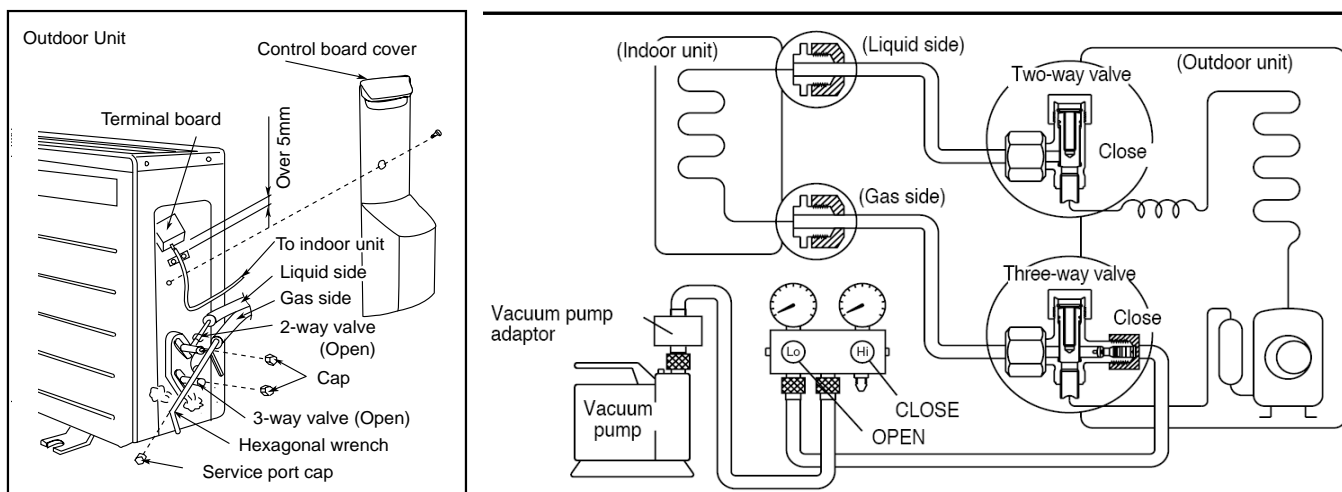

- 1 Connect a charging hose with a push pin to the low side of a charging set and the service port at the 3-way valve.
  - Be sure to connect the end of charging hose with the push pin to the service port.
  - The size of charging hose fitting should be 1/2 UNF, 20 threads.
- 2 Connect the center hose of the charging set to a vacuum pump with check valve, or vacuum pump and vacuum pump adaptor.
- 3 Turn on the power switch of the vacuum pump and make sure that the needle in the gauge moves from 0 cmHg (0 Mpa) to -76 cmHg (-0.1 Mpa). Then evacuate the air approximately ten minutes.
- 4 Close the Low side valve of the charging set and turn off the vacuum pump. Make sure that the needle in the gauge does not move after approximately five minutes.
 







Note: BE SURE TO FOLLOW THIS PROCEDURE IN ORDER TO AVOID REFRIGERANT GAS LEAKAGE
- 5 Disconnect the charging hose from the vacuum pump and from the service port of the 3-way valve.
- 6 Tighten the service port caps of the 3-way valve at a torque of 18 N.m with a torque wrench.
- 7 Remove the valve caps of both of the 2-way valve and 3-way valve. Position both of the valves to "OPEN" using a hexagonal wrench (4mm).
- 8 Mount valve caps onto the 2-way and the 3-way valve.
  - Be sure to check for gas leakage.

**CAUTION:**

- If gauge needle does not move from 0 cmHg (0 MPa) to -76 cmHg (-0.1 MPa), in step 3 above take the following measure:
- If the leak stops when the piping connections are tightened further, continue working from step 3.
- If the leak does not stop when the connections are retightened, repair the location of leak.
- Do not release refrigerant during piping work for installation and reinstallation. Take care of the liquid refrigerant, it may cause frostbite.

### 10.3.4 Connect the cable to the Outdoor Unit

- 1 Remove the control board cover from the unit by loosening the screw.
- 2 Connecting cable between indoor unit and outdoor unit shall be approved polychloroprene sheathed 4x 1.5mm<sup>2</sup> flexible cord, type designation 245 IEC 57 or heavier cord.

Terminals on the indoor unit	1(L)	2(N)	3	
Colour of wires				
Terminals on the outdoor unit	1(L)	2(N)	3	

- 3 Secure the cable onto the control board with the holder (clammer).
- 4 Attach the control board cover back to the original position with the screw.

### 10.3.5 Pipe Insulation

- 1 Please carry out insulation at pipe connection portion as mentioned in Indoor/Outdoor Unit Installation Diagram. Please warp the insulated piping end to prevent water from going inside the piping.
- 2 If drain hose or connecting piping is in the room (where dew may form), please increase the insulation by using POLY-E-FOAM with thickness 6mm or above.



## 11. Service Mode

### 11.1 Auto OFF/ON Button

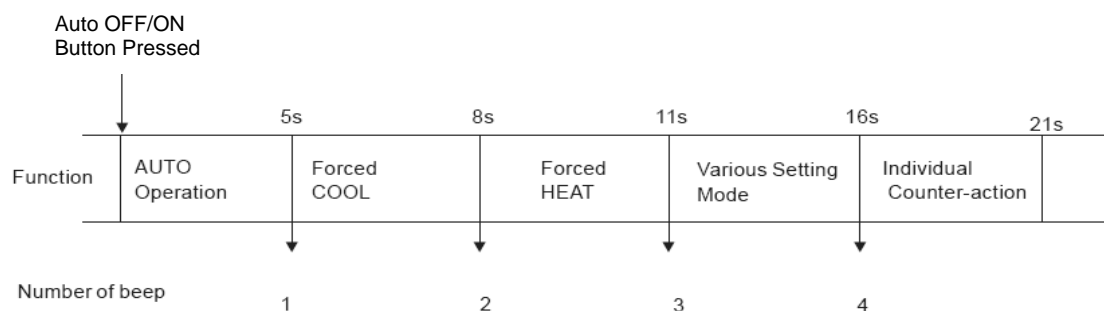

1. **AUTO OPERATION MODE**  
Once the Auto OFF/ON button is slightly pressed, the unit will immediately operate in Auto operation. This operation can be used to operate air conditioner with limited function if remote control is misplaced or malfunction.
2. **TEST RUN OPERATION( FOR PUMP DOWN/ SERVICING PURPOSE)**  
Press the button continuously for approximate 5 second and then release. A “beep” sound will be heard to identify the starting of TEST RUN OPERATION.
3. **HEATING OPERATION**
  - A) Within 5 minutes after TEST RUN operation starting, press the button again for more than 5 seconds until 2 “beep” sounds are heard, the unit will operate in heating mode.
  - B) Pressed the button continuously for approximate 8 second and then released. 2 “beep” sounds will be heard to identify the starting of HEATING operation.
4. **DIFFERENT CONTROLLING SETTING.**  
Press the button continuously for approximate 11 until 3 “beep” sounds are heard and together with the signal from remote controller, the unit can be changed to different controlling setting.  
For transmission code selection method, please refer to “Select Remote Control Transmission Code”
5. **INDIVIDUAL COUNTER-ACTION**  
When the switch is continuously pressed between 16 to 21 seconds, either H14 error detection selection mode or remote controller’s signal receiving sound can be cancelled or turned on.

### 11.2 Select Remote Control Transmission Code

- ✧ There are 4 types of remote control transmission code could be selected and stored in EEPROM of indoor PCB. The indoor unit will only operate when received signal with same transmission code from remote control. This could prevent signal interference when there are 2 or more indoor units installed near by together.
- ✧ To Change the code of remote controller, following table I to join or cut jumper wire on the remote controller and setting with "Forced operation button". Four codes (A, B, C, D) can be selected. Taking code "B" for example, the process below should be follow.
  1. Press the "Auto OFF/ON" button on the indoor unit for approximate 11 seconds until 3 "Beep's signal receiving sounds are heard.
  2. Within 5 minutes, gently press the "RESET" button on the remote control towards the indoor unit. One "Beep" sound is heard.
  3. Within 60 seconds, press any button on the remote control, the frequency of which was set as "B". Setting is completed after a "Beep" sound is heard. The corresponding signal sent by remote control "B" will be received by this indoor unit

Table 1

Remote control	J02	J03
A(STANDARD)	SHORT	OPEN
B	OPEN	OPEN
C	SHORT	SHORT
D	OPEN	SHORT

## 11.3 Operate and Display of Remote Control

### 11.3.1 Original setting



### 11.3.2 Mode selecting button

AUTO, HEAT, COOL, DRY can be selected by pressing "MODE" button. Initial display of LCD is as follow

MODE	SET TEMP	FAN SPEED	AIR SWING
AUTO	25°C	AUTO	AUTO
HEAT	22°C	AUTO	AUTO
COOL	27°C	AUTO	AUTO
DRY	25°C	AUTO	AUTO

\*Keeping the button depressed continuously, the operation mode will change in the following order in turn  
 AUTO—HEAT—COOL—DRY--AUTO

### 11.3.3 Temperature adjusting button

Temperature adjusting range is between 16°C~30°C

### 11.3.4 Fan speed button

There are 5 speed levels can be selected. The display on the remote controller changes as follows by pressing the AIR SWING button.



### 11.3.5 AIR SWING button

To adjust vertical airflow directions by pressing AIR SWING button (5 options)

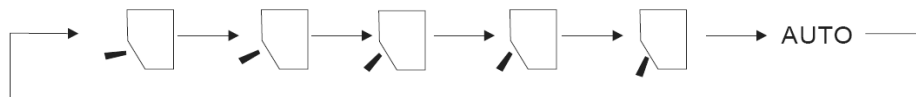

### 11.3.6 QUIET/POWERFULL button

Press this button to switch among QUIET operation, POWERFUL operation and normal operation.

**Start Quiet operation:** Press this button until "QUIET" displaying on remote control display and indoor QUIET indicator will light up to identify Quiet mode operating.

**Start POWERFUL operation:** Press this button until POWERFUL displays on remote control display and indoor POWERFUL indicator will light up to identify Quiet mode operating.

**Switch Quiet /Powerful operation to normal operation:** Press this button until "QUIET" and "POWERFUL" on remote control display disappear. Indoor unit's "QUIET" and "POWERFUL" indicators will go out to identify the unit returns to normal operation.

**Note:** QUIET and POWERFUL operation can not be active simultaneously.

### 11.3.7 Timer setting button

There are 4 types of timer setting by pressing Timer setting button: ON-TIMER, OFF-TIMER, ON-OFF TIMER, OFF-ON TIMER.

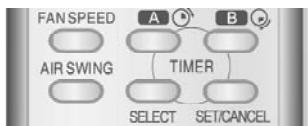

#### 1) SELECT button

When the air conditioner is ON, OFF-TIMER or OFF-ON TIMER can be selected by pressing SELECT button.

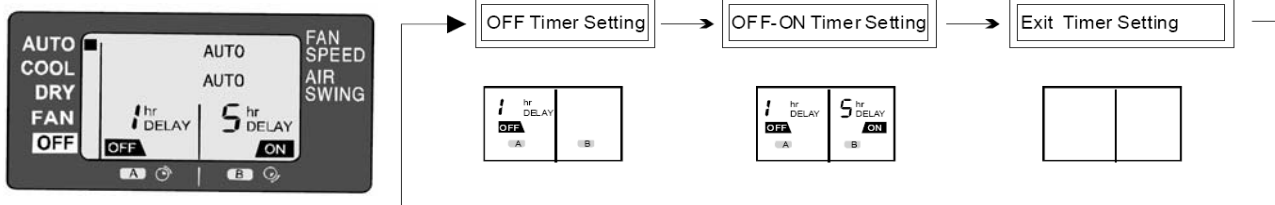

When the air conditioner is turned off, ON-TIMER or ON-OFF-TIMER can be selected.

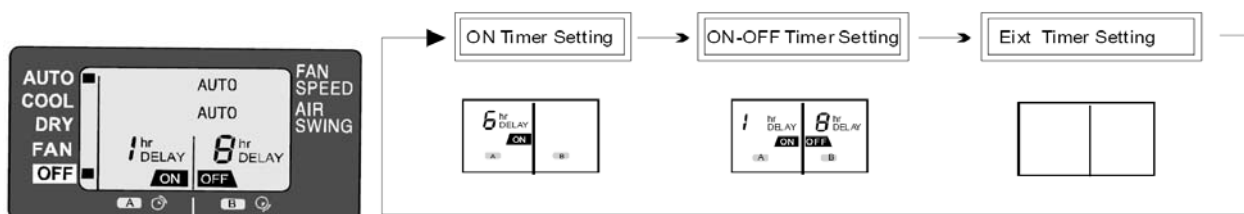

#### 2) Button A and B

Pressing button A can change the time for ON-TIMER and OFF-TIMER, off time for OFF-ON Timer, on time for ON-OFF TIMER; Pressing button B can change the on time for OFF-ON Timer and off time for ON-OFF Timer setting.

#### 3) SET/CANCEL button.

Pressing the button to set or cancel the set timer during the timer setting or activate the previous timer setting. After the timer setting is determined, "ON" or "OFF" will stop flashing. If the timer setting is cancelled, "ON" or "OFF" will disappear on the remote control display.

#### NOTE:

- ✧ OFF Timer and OFF- ON Timer can only be set during the operation;
- ✧ Timer setting can operate only once.
- ✧ If the OFF/ON button on the remote control or the AUTO Switch on the indoor unit is pressed, the timer setting will be cancelled.
- ✧ If Auto Restart Control occurs, timer setting will be cancelled.
- ✧ During the operation, if the ON Timer or ON-OFF Timer is set, the operation will be stopped.

### 11.3.8 About Cursor Key Which Points To "OFF" On Remote Control

When the ON/OFF button on the remote control is pressed, the cursor key which points to "OFF" will appear or Disappear to indicate the ON/OFF status of the air conditioner.



For some reason (Ex. The signal of the remote control does not reach the signal receiver of the indoor unit.), the display of the remote control will not correspond with the actual ON/OFF status of the indoor unit:

1. The air conditioner is running but the cursor key which points to "OFF" appears. The air conditioner can be stopped with any button (Except for "ON/OFF", "TIMER SET", "TIMER ON") pressed.
2. The air conditioner is on standby, but the cursor key which points to "OFF" disappears. The air conditioner can be started with any button (Except for "ON/OFF", "TIMER SET", "TIMER OFF") pressed.

## 12. Operation Control

### 12.1 Basic Function

#### 12.1.1 Internal Setting Temperature

Once the operation starts, remote control setting temperature will be taken as base value for temperature shifting processes. These shifting processes are depending on the air conditioner settings and the operation environment. The final shifted value will be used as internal setting temperature and it is updated continuously whenever the electrical power is supplied to the unit.

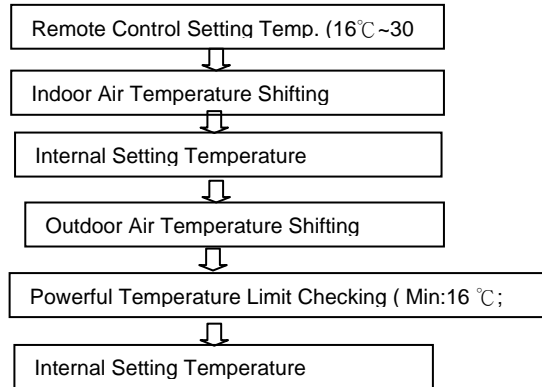

#### 12.1.2 Cooling Operation

##### 12.1.2.1 Thermostat control

- Compressor is OFF when Intake Air Temperature - Internal Setting Temperature < -1.5°C
- Compressor is ON after waiting for 3 minutes, if the Intake Air Temperature - Internal Setting Temperature > Compressor OFF point.

#### 12.1.3 Soft Dry Operation

##### 12.1.3.1 Thermostat control (The same as Cooling mode)

#### 12.1.4 Heating operation

##### 12.1.4.1 Thermostat control

- Compressor is OFF when Intake Air Temperature - Internal Setting Temperature > +2.0°C
- Compressor is ON after waiting for 3 minutes, if the Intake Air Temperature - Internal Setting Temperature < Compressor OFF point.

#### 12.1.5 Automatic Operation

1. Once AUTO mode is selected, operation mode is determined by set temperature of remote control, indoor intake temperature and outdoor temperature.

2. During operating mode judgment, indoor fan runs at minLo- fan speed and outdoor fan runs in the purpose of detecting the intake air temperature and outdoor air temperature (for 30 seconds)

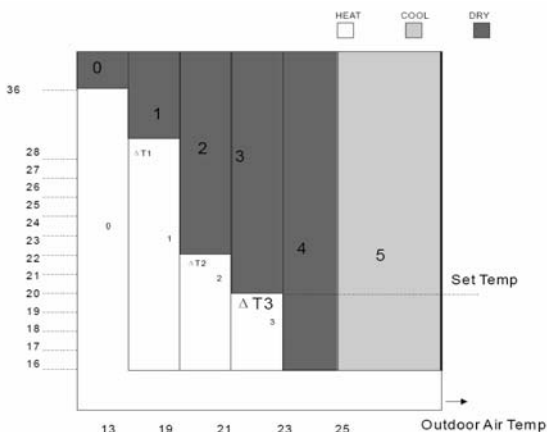

$$\text{Set Temp} = \text{Remote Set Temp} + \Delta T$$

Set Temp on Remote Control	$\Delta T1$	$\Delta T2$	$\Delta T3$
16, 17, 18	+10	-3	-5
19, 20, 21, 22	+8	-3	-7
23, 24, 25, 26	+7	-3	-7
27, 28, 29, 30	+6	-3	-8

If the operation mode changed,  $\Delta T1$ ,  $\Delta T2$ ,  $\Delta T3$  will change as follow:

Cooling /Soft Dry → Heating Operation: -2°C

Heating → Cooling /Soft Dry Operation: +2°C

## 12.2 Indoor Fan Motor Operation

### Basic Rotation Speed

i. Manual Fan speed

Fan motor's number of rotation is determined according to remote control setting.

Model	Remote control	O	O	O	O	O
	Tab	Hi	Me+	Me	Me-	Lo
CS-RE9HKE	COOLING(rpm)	1360	1190	1070	950	830
	HEATING(rpm)	1420	1270	1150	1030	910
CS-RE12HKE	COOLING(rpm)	1370	1270	1160	1050	940
	HEATING(rpm)	1440	1340	1260	1180	1100

ii. Auto Fan Speed (Cooling, Soft Dry Mode)

According to room temperature and setting temperature, indoor fan speed is determined automatically. The indoor fan will operate according to pattern below.

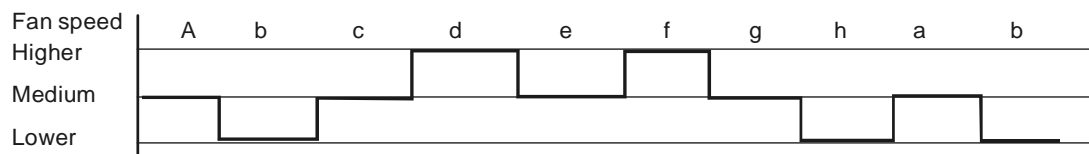

### B. Feedback control

- Immediately after the fan motor started, feedback control is performed once every second.
- During fan motor on, if fan motor feedback 2550 rpm or < 50 rpm continue for 10 seconds, then fan motor error counter increases, fan motor then stops and restarts. If the fan motor counter becomes 7 times, then H19 - fan motor error is detected. Operation stops and cannot on back.

## 12.3 Outdoor Fan Motor Operation

Outdoor fan motor is operated with one fan speed only. It starts when compressor starts operation and it stops 30 seconds after compressor stops operation.

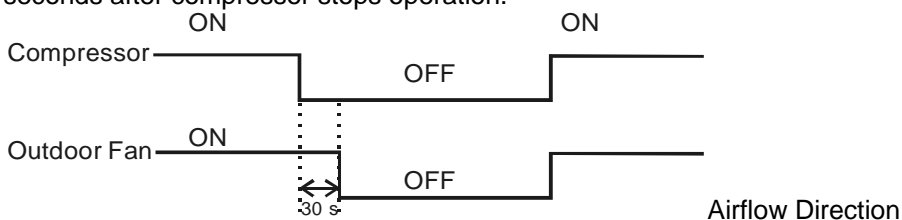

### 12.3.1 Vertical Airflow

Operating Mode		1	2	3	4	5	
Cooling	Manual	10°	22°	31°	40°	50°	
	Auto	Normal	10° ~50°				
		Powerful	35°(Beginning of POWERFUL mode) , 6°				
Soft dry	Manual	10°	22°	31°	40°	50°	
	Auto	Normal	12°				
		Powerful	12°				
Heating	Manual	8°	24°	37°	51°	63°	
	Auto	Normal	8°, 9°, 39°, 41° ,				
		Powerful	8°, 9°, 35°, 39° ,				

1. Automatic vertical airflow direction can be set using remote control; the vane swings up and down within the angles as stated

above. For heating mode operation, the angle of the vane depends on the indoor heat exchanger temperature. When the air conditioner is stopped using remote control, the vane will shift to close position.

2. Manual vertical airflow direction can be set using remote control. The angels of the vane are as stated above. When the air conditioner is stopped using remote control, the vane will shift to close position.

### 12.3.2 Horizontal Airflow

The horizontal airflow direction louvers can be adjusted manually by hand.

### 12.3.3 Quiet operation

- To provide quiet operation comparing to normal operation. The Quiet operation can be active or stop by pressing QUIET/POWERFUL buttons at remote control.
- Once Quiet mode is active ,the unit will continuously operate in QUIET Mode until cancel the mode by pressing QUIET/POWERFUL buttons at remote control.

### 12.3.4 Powerful operation

- To cooling or heating the room faster comparing to normal operation. The POWERFUL operation can be active or stop by pressing QUIET/POWERFUL buttons at remote control.
- When powerful operation is active, the unit will continuously operate in POWERFUL mode until cancel the mode by pressing QUIET/POWERFUL buttons at remote control. Operation details are as the fig. below.

1. For cooling, soft Dry mode

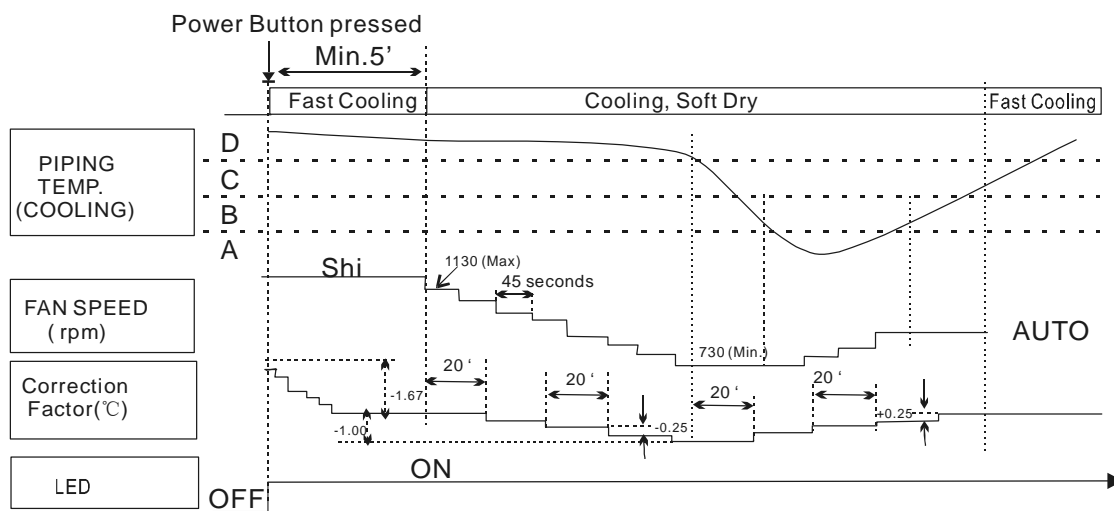

2. For Heating mode:

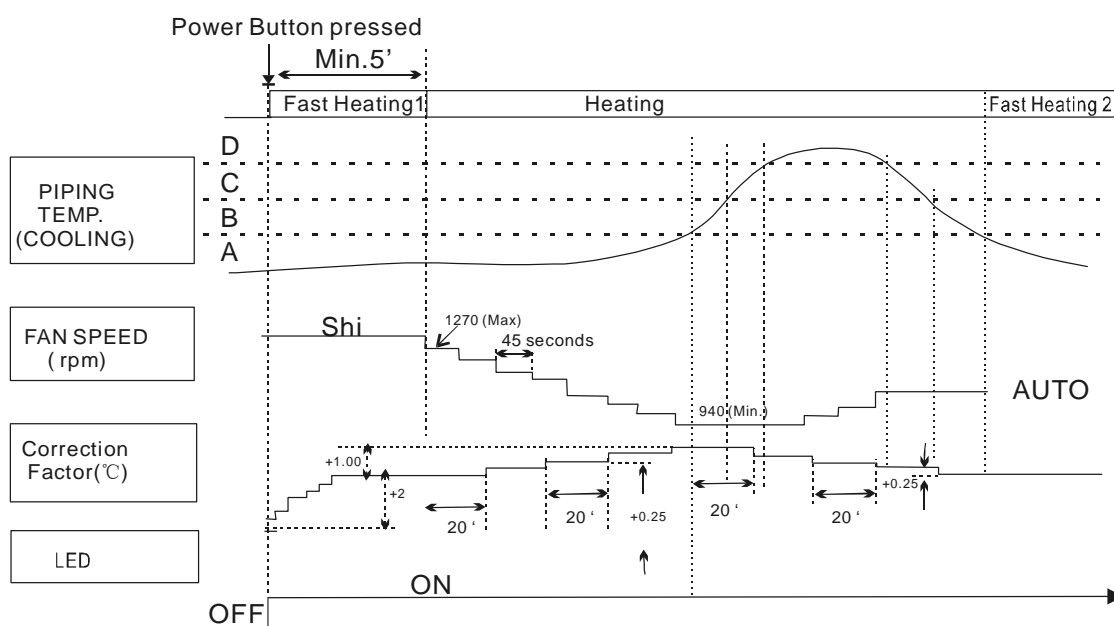

Note: The value of A, B, C, D will change according to the indoor temperature.

### 12.3.5 Automotive Restart Control

When the power supply is cut off during the operation of air conditioner, the compressor will re-operate within three to four minutes after power supply resumes.

### 12.3.6 Indication Panel

LED	POWER	TIMER	POWERFUL	QUIET
Color	Green	Orange	Red	Green
Light ON	Operation ON	Timer setting ON	Powerful Mode ON	Quiet mode ON
Light OFF	Operation OFF	Timer setting OFF	Powerful Mode OFF	Quiet mode OFF

Note:

- If POWER LED blinks, the possible operation of the unit is operation mode judgment, or ON timer sampling.
- If Timer LED blinks, there is an abnormal operation occurs.

### 12.3.7 Timer control

Delay ON Timer can be set using remote controller, the unit with timer set will start operate earlier than the setting time. This is to provide a comfortable environment when reaching the set On time. Seventy minutes before the set time for ON Timer or ON-OFF Timer setting, indoor ( at fan speed of Lo-) and outdoor fan motor start operate for 30 seconds to determine the indoor intake air temperature and outdoor air temperature in order to judge the operation mode. From the above judgment, the decided operation will start operate earlier than the set time as shown below.

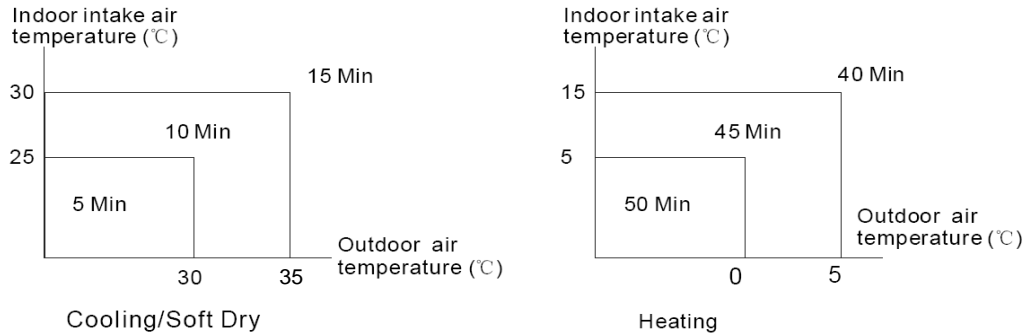

Timer Signal Receiving sound During Operation.

	Operation	Sound	Timer LED	Timer Setting
ON Timer Set	OFF	Beep-	ON	Valid
OFF Timer Set	ON	Beep	ON	Valid
ON-OFF Timer Set	OFF	Beep-	ON	Valid
OFF-ON Timer Set	ON	Beep	ON	Valid

Timer Signal Receiving Sound When the Air Conditioner Stops.

	Operation	Sound	Timer LED	Timer Setting
ON Timer Set	OFF	Beep	ON	Valid
OFF Timer Set	OFF	None	OFF	Invalid
ON-OFF Timer Set	OFF	Beep	ON	Valid
OFF-ON Timer Set	OFF	None	OFF	Invalid



## 13. Protection control

### 13.1 Protection Control For All Operations

#### 13.1.1 Time Delay Safety Control

- The Compressor will not turn on within 3 minutes from the moment operation stops, although the unit is turned on again by pressing OFF/ON button at remote control within this period.
- This control is not applicable if the power supply is cut off and on again.
- This phenomenon is to balance the pressure inside the refrigerant cycle.

#### 13.1.2 30 Seconds Forced Control

- Once the air conditioner is turned on, the compressor will not stop within 30 seconds in a normal operation although the intake air temperature has reached the thermo-off temperature. However, force stop by pressing the OFF/ON button at the remote control is permitted or the Auto OFF/ON button at indoor unit.
- The reason for the compressor to force operation for minimum 30 seconds is to allow the refrigerant oil run in a full cycle and return back to the outdoor unit.

#### 13.1.3 Total running current control

1. If the outdoor unit total running current is detected exceeding  $I_1(A)$ , the frequency instructed for compressor operation will be decreased.
2. If the running current does not exceed  $I_1(A)$  for 5 seconds, the frequency instructed will be increased.

Operation mode	RE9HKE	RE12HKE
	$I_1(A)$	$I_1(A)$
Cooling/ Soft Dry /Fan A*	5.8	7.4
Cooling/ Soft Dry /Fan B	5.6	7.3
Heating	7.01	8.05

\*The first 30 minutes of cooling operation, A will be applied.

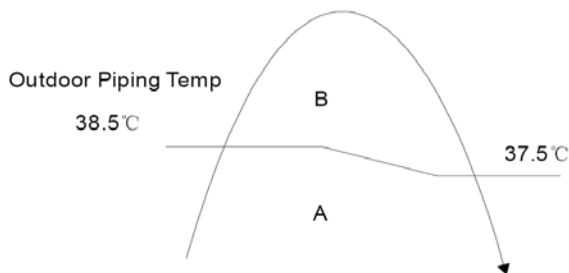

#### 13.1.4 IPM (Power transistor) Protection Control.

1. DC Peak Current Control
  - When electric current to IPM exceeds set value of DC17.3 1A, the compressor will stop. It will restart after three minutes.
  - If the set value is exceeded again within 30 seconds, the operation will restart after one minute.
  - If this condition repeats continuously for seven times, all indoor and outdoor relays will be cut off.
  - Error code [F99] will be displayed.
2. Overheating protection control
 

When the IPM temperature rises to 90.0°C , compressor will stop immediately.  
Compressor restarts after three minutes if the temperature decreases to 85°C

#### 13.1.5 Compressor Overheating Prevention Control

Instructed frequency for compressor operation will be regulated compressor discharge temperature. The change of frequency is as below.

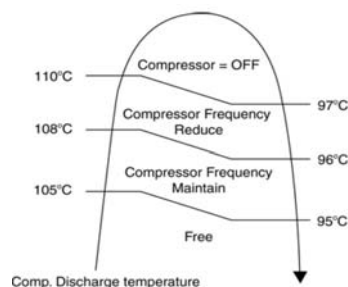



### 13.1.6 Low pressure Prevention control (Gas Leakage Detection)

1. When the conditions listed in the table occur, the compressor stops and restarts after three minutes.
2. If this continuously occurs for twice within 20 minutes, all indoor and outdoor relays will be cut off.
3. This control is not applicable for deice operation.

Comp Frequency	45Hz or Above	64Hz or Above	58Hz or Above	73Hz or Above
Total Outdoor Current	$1b \leq I < 1.3$	$1b \leq I < 1.6$	$1b \leq I < 1.3$	$1b \leq I < 1.6$
Indoor Piping Temp	20°C or Above	25°C or Less	20°C or Above	25°C or Less
Operation Mode	Cool/Dry	Heat	Cool/Dry	Heat
Model	RE9HKE		RE12HK	

### 13.1.7 Low Operation Frequency Protection Control

If one of the following conditions exists, the compressor will run with the frequency of 40 Hz

Intake Air Temp	$\geq 30^\circ\text{C}$ or $< 15^\circ\text{C}$	————
Outdoor Temp	$\geq 38^\circ\text{C}$ or $< 16^\circ\text{C}$	$\geq 24^\circ\text{C}$ or $< 4^\circ\text{C}$
Indoor Piping Temp	$< 30^\circ\text{C}$	$\geq 0^\circ\text{C}$
Operation Mode	Cool/Dry	Heat

### 13.1.8 Compressor Tank Temperature Rise Protection Control

a. Control start conditions

- For 5 minutes, the compressor continuously operates and outdoor total current is between 0.65A and 1.65A.
- During Cooling and Soft Dry operations:
  - Indoor suction temperature - indoor piping temperature is below 4°C.
  - Indoor temperature and outdoor temperature is  $30 \pm 5^\circ\text{C}$ .
  - Remote Control setting 16°C and Hi Fan Speed.
- During Heating operations:
  - Indoor piping temperature - indoor suction is under 5°C.
  - Indoor temperature and outdoor temperature is  $20 \pm 2^\circ\text{C}$ .
  - Remote control setting 30°C and Hi Fan Speed.

b. Control contents

- Compressor stops (and restart after 3 minutes)
- If the conditions above happen 2 times within 20 minutes, the unit will:
  - Stop operation
  - Timer LED blinks and "F91" indicated

## 13.2 Protection Control For Cooling and Soft Dry Operation

### 13.2.1 Outdoor Air Temperature Control

- The compressor operating frequency is regulated in accordance to the outdoor air temperature as shown in the diagram below.
- This control will begin 1 minute after the compressor starts.
- Compressor frequency will adjust base on outdoor air temperature.

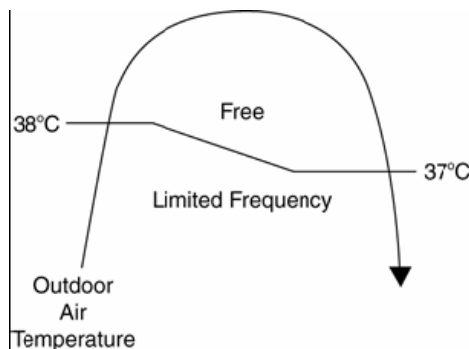

### 13.2.2 Freeze Prevention Control

#### 1. Frequency of the compressor

For prevention of freezing of the indoor evaporator, the frequency of the compressor will be changed according to the indoor piping temperature.

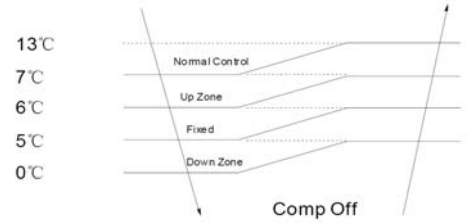

#### 2. Indoor Fan Control

Indoor fan speed changes according to the indoor fan speed.

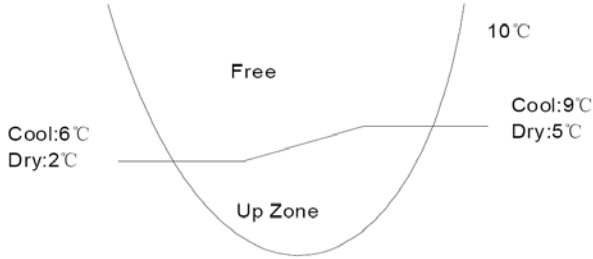

### 13.2.3 Dew Prevention Control

- To prevent dew formation at indoor unit discharge area.
- This control starts if all conditions continue for 20 minutes:
  - Operated with Cooling or Soft Dry Mode.
  - Indoor intake temperature is between 25°C and 29°C.
  - Outdoor air temperature is less than 30°C.
  - Quiet Lo fan speed.
- This control stopped then receive air swing change signal from Remote Control.

### 13.2.4 Overload Protection For Cooling Operation

The frequency for the compressor will change according to the outdoor piping temperature.

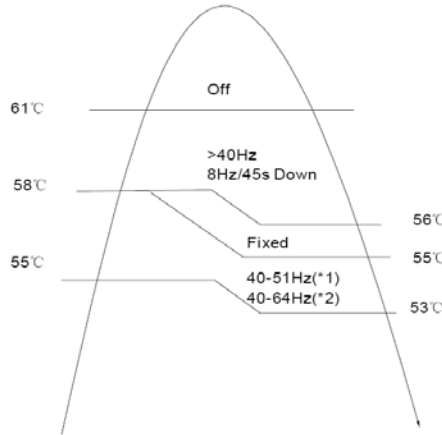

## 13.3 Outdoor Air Temperature Control

### 13.3.1 Indoor Fan Control

1. Indoor fan is controlled by the indoor piping temperature.

- Manual Fan Speed

Piping Temperature(°C)

K0	K1	K2	K3	K4	K5	K6	K7	K8	K9	K10	K10
16	19	24	322	342	35	36	39	42	55	55	58

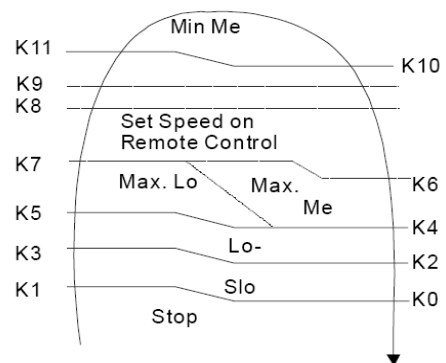

● Auto Fan Speed

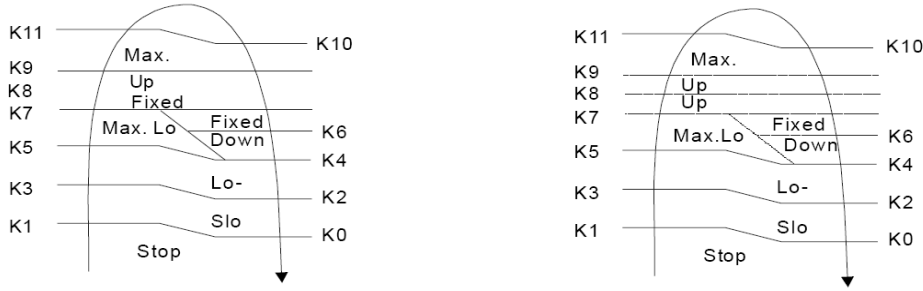

2. During heating operation, the indoor fan will run at the following speed when the compressor stops.

	1	2	3	4	5	6	7	8
Comp.	ON		OFF					
Fan speed (rpm)	Control by piping temp.		480	460	480	460	480	460
Time (Second)	—		20	100	20	100	20	100

3. Hot Start

When the heating operation starts, the indoor fan stops and the compressor run with the frequency of 117Hz. This is to prevent the cold airflow from blowing.

If the piping temperature rises to 19 °C, and the indoor fan speed and airflow direction varies with the indoor piping temperature, the hot start control is completed.

13.3.2 Overload Protection Control

The frequency for the compressor is determined by indoor piping temperature.

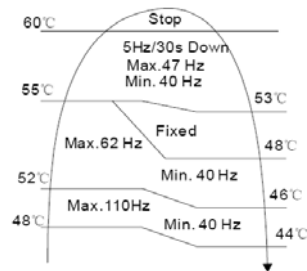

13.3.3 Outdoor Air Temp Control

One minute after the start-up of the compressor, outdoor air temperature control starts.

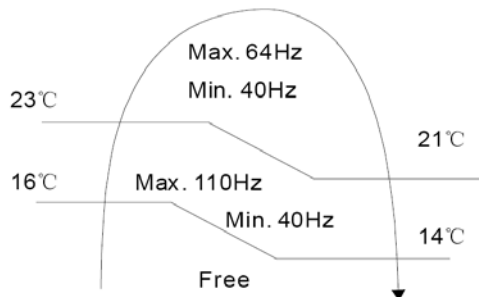

## 14. Troubleshooting Guide

### 14.1 Refrigeration cycle system

In order to diagnose malfunctions, make sure that there are no electrical problems before inspecting the refrigeration cycle. Such problems include insufficient insulation, problem with the power source, malfunction of a compressor and a fan. The normal outlet air temperature and pressure of the refrigeration cycle depends on various conditions, the standard values for them are shown in the table on the right.

Normal Pressure and Outlet Air Temperature (Standard)

	Gas Pressure Mpa (kg/cm <sup>2</sup> G)	Outlet air Temperature (°C)
Cooling Mode	0.9~1.2 (9~12)	12~16
Heating Mode	2.3 ~2.9 (23~29)	36~45

Condition: Indoor fan speed = High  
 Outdoor temperature = 35°C at cooling mode and 7°C at heating mode.  
 Compressor operates at rated frequency

#### 14.1.1

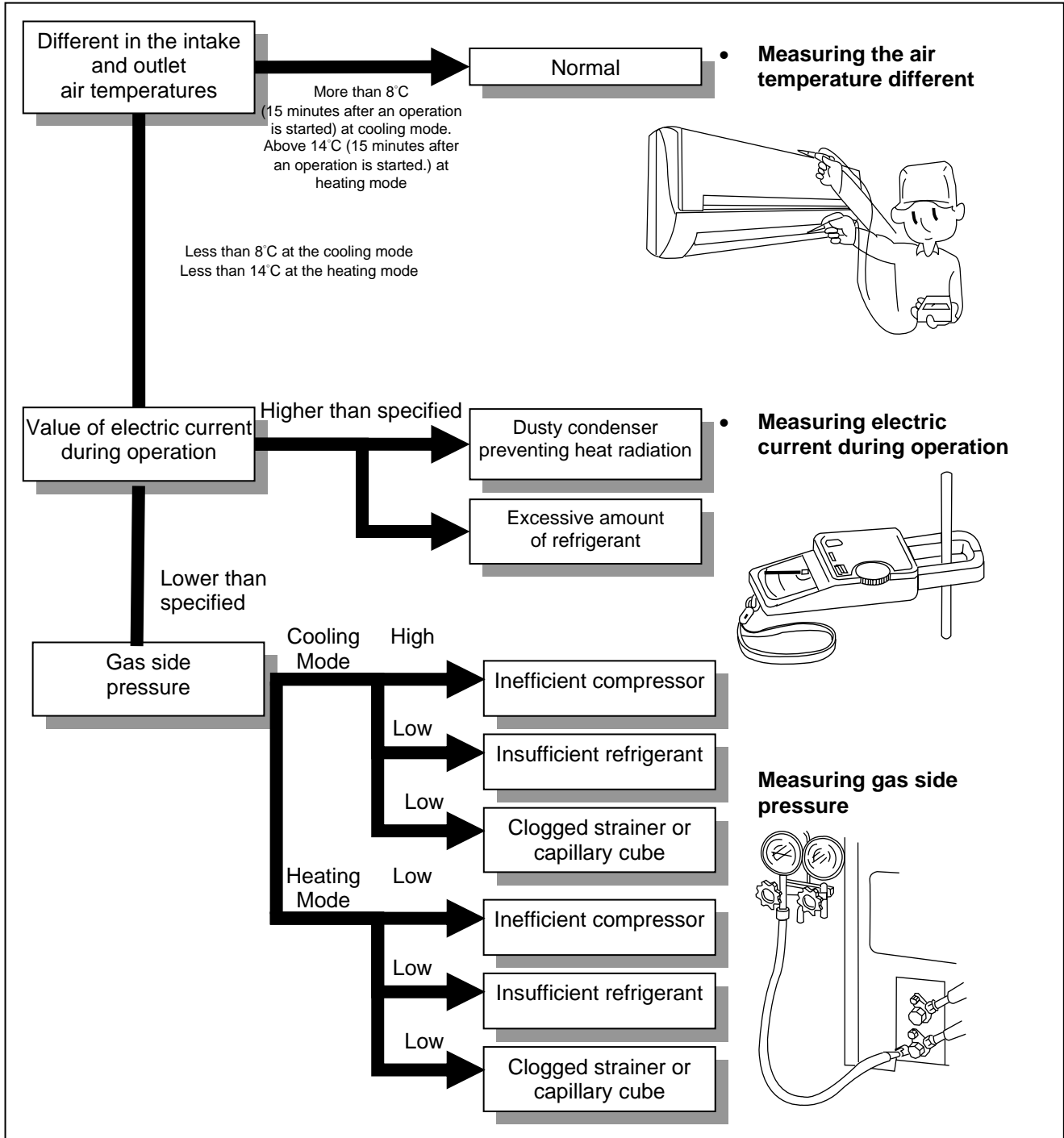

## 14.1.2 Relationship between the condition of the air conditioner and pressure and electric current

Condition of the air conditioner	Cooling Mode			Heating Mode		
	Low Pressure	High Pressure	Electric current during operation	Low Pressure	High Pressure	Electric current during operation
Insufficient refrigerant (gas leakage)	↘	↘	↘	↘	↘	↘
Clogged capillary tube or strainer	↘	↘	↘	↗	↗	↗
Short circuit in the indoor unit	↘	↘	↘	↗	↗	↗
Heat radiation deficiency of the outdoor unit	↗	↗	↗	↘	↘	↘
Inefficient compression	↗	↘	↘	↗	↘	↘

• Carry out the measurement of pressure, electric current, and temperature fifteen minutes after an operation is started.

## 14.2 Breakdown Self Diagnosis Function

### 14.2.1 About Self Diagnosis

When the air-conditioner is stopped due to malfunction detected by itself, the operation can be restarted using AUTO Switch on the indoor unit. In forced operation, the frequency for compressor and fan speed can not be changed and the signal receiving sound is different.

Normal Operation ON: "pep"

Forced Operation ON: "pep", "pep", "pep", "pep"

Stop: "pep"

Note: Refer to the Diagnosis Code Table for the malfunction when forced operation is not available.

### 14.2.2 Display of Error Code

1. Keeping the CHECK button on the remote controller depressed for 5 seconds, error code ranging from H11 to H99 can be displayed on the remote controller.
2. The error code is changed and diagnosis signal is transmitted to the indoor unit by pressing the Temp Up button on the remote control.
3. When the malfunction of the air-conditioner matches the error code on the remote control, four beeps can be heard from the indoor unit and the operation indicator will light up.
4. Keep the CHECK button depressed continuously for 5 seconds to cancel the diagnosis function.

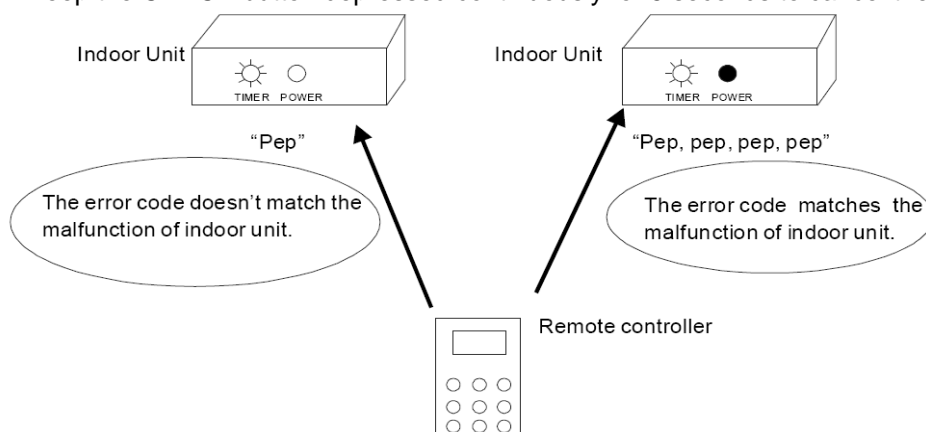

### 14.2.3 Error Codes Table

Code	Abnormality/Protection	Judgment	Check	Emergency Operation
H00	Normal			
H11	Indoor/Outdoor abnormal communication	>1minute after starting operation	Connecting cable, Indoor /outdoor PCB	○
H14	Indoor intake air temp sensor abnormality	-	Intake air temperature sensor( defected or disconnected)	X
H15	Outdoor compressor temperature sensor abnormality	Continue for 5 sec.	Compressor temperature sensor(defected or disconnected)	X
H16	Outdoor Current Transformer open circuit	-	Outdoor PCB, IPM module	X
H19	Indoor fan motor mechanism lock	-	Indoor PCB, fan motor	X
H23	Indoor heat exchanger temperature A sensor abnormality	Continue for 5 sec	Heat exchanger temperature sensor (defected or disconnected)	○
H25	Air filter abnormality	-		○
H27	Outdoor air temperature sensor abnormality	Continue for 5 sec	Outdoor temperature sensor( defected or disconnected)	○
H28	Outdoor heat exchanger temperature sensor abnormality	Continue for 5 sec.	Outdoor heat exchanger sensor (defected or disconnected)	○
H30	Discharge temperature sensor abnormality	Continue for 5 sec.	Discharge temperature sensor (defected or disconnected)	○
H33	Incorrect connection of Indoor/Outdoor cable	-	Indoor/outdoor supply voltage	X
H97	Outdoor fan motor lock	Twice within 30 minutes	Outdoor fan motor	X
H98	Indoor high pressure protection	-	Air filter dirty Air circulation short circuit	-
H99	Indoor heat exchanger anti-freezing protection	Indoor heat exchanger freezing	Insufficient refrigerant Air filter dirty	-
F11	Cooling/heating cycle changeover abnormality	4 times occurrence within 30 minutes	4-way valve V-coil	X
F16	Cooling/Dry cycle changeover abnormality	4 times occurrence within 30 minutes	Indoor PCB	X
F90	PFC control	4 times occurrence within 20 minutes	Voltage at PFC	X
F91	Refrigeration cycle abnormality	2 times occurrence within 20 minutes	No refrigerant (3-way valve is closed)	X
F93	Compressor abnormality	4 times occurrence within 20 minutes	Compressor	X
F95	Cool high pressure protection	4 times occurrence within 20 minutes	Outdoor refrigeration cycle	X
F96	IPM overheating protection	-	Excessive refrigerant Improper heat radiation IPM	X
F97	Outdoor compressor overheating protection	4 times occurrence within 20 minutes	Insufficient refrigerant Compressor	X
F98	Total running current protection	3 times occurrence within 20 minutes	Excess refrigerant Improper radiation	X
F99	Outdoor Peak Current Protection Control	4 times occurrence continuously within 30 minutes	Outdoor PCB IPM Compressor	X

## 15. Disassembly and Assembly Instructions

 **WARNING**

High Voltage is generated in the electrical parts area by the capacitor. Ensure that the capacitor has discharged sufficiently before proceeding with repair work. Failure to heed this caution may result in electric shocks.

**Removal Procedure For Intake Grille**

1. Open the intake grille and pull it to the horizontal position. (Fig. 1)



Fig. 1

2. Pull up the intake grille until it falls off. (Fig. 2)

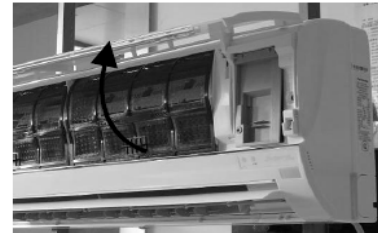

Fig. 2

**Removal Procedure For Front Grille**

1. Remove the two caps at the discharge port (right and left) (Fig. 3)

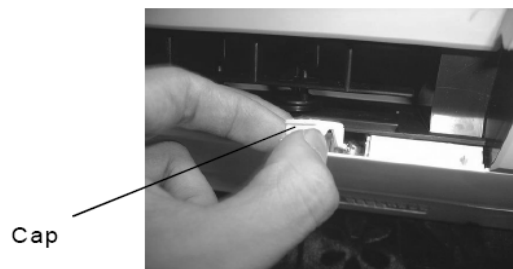

Fig. 3

2. Release the two screws under the both caps. (Fig. 4)

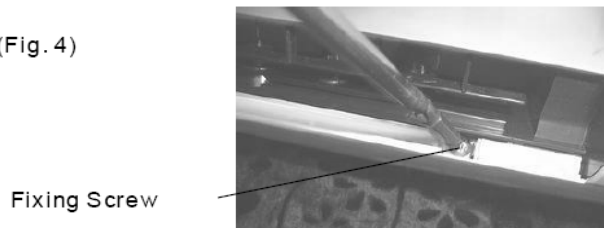

Fig. 4

3. Pull out the front grille from the unit body. (Fig. 5)

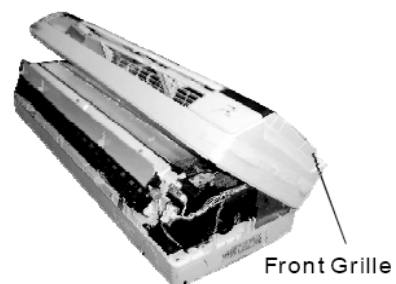

Fig. 5



**Removal Procedure For Electronic Controller**

1 Remove indicator complete

Afer removing the front grille, loose the screw behind the indicator, the whole indicator can be released.

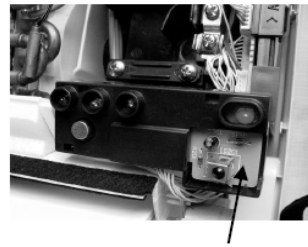

Fig 6 Indicator Complete

2 Remove the cover of control board and holder

3 Break off the earing ,release the holder slightly.

Be sure to avoid cracking of the holder.

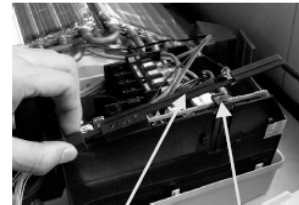

Fig 7 Holder Earing

4. Release the lead wire CN-FM, CN-STM, CN-DISP and earth wire(Yellow/Green). Take out the sensor from the socket. Pull out the whole electronic controller.

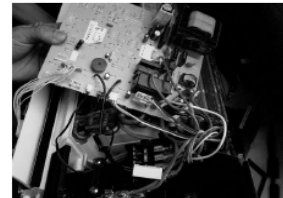

Fig 8

5. Remove the whole control board

Loose the screws of control board,earings slightly, then the whole control board can be pulled out.

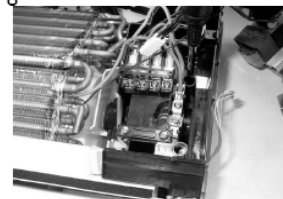

Fig 9

**Removal Procedure For the Discharge Grille**

1. Separate the drain hose and the drain plate(Fig.10)

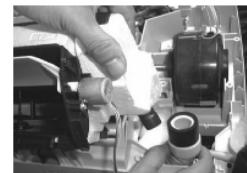

Fig 10

2. Pull out the discharge grille slightly (Fig. 11)



Fig. 11



**Removal Procedure For Cross Flow Fan**

1. Release the two fixing screws, disassembly the fixing board from evaporator on the left side of the evaporator and pull out the whole evaporator. (Fig. 12)



Fig. 12

2. Loose the fixing screw of the cross flow fan. (Fig. 13)



Fixing Screw

Fig. 13

3. After removing the bearing (refer to fig14) , indoor fan can be taken out from the left side.

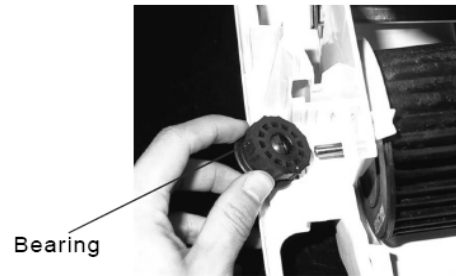

Bearing

Fig 14

4. Lift up the indoor fan slightly, and then pull the fan motor out. Fig15

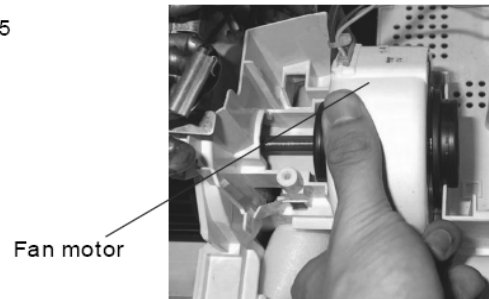

Fan motor

Fig 15

**Remote control reset**

If the display is chaotic or can not be adjusted, Use a pin to press RESET button to reset the remote control to the original set by manufacture.

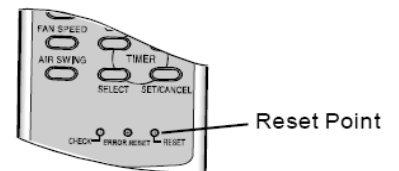
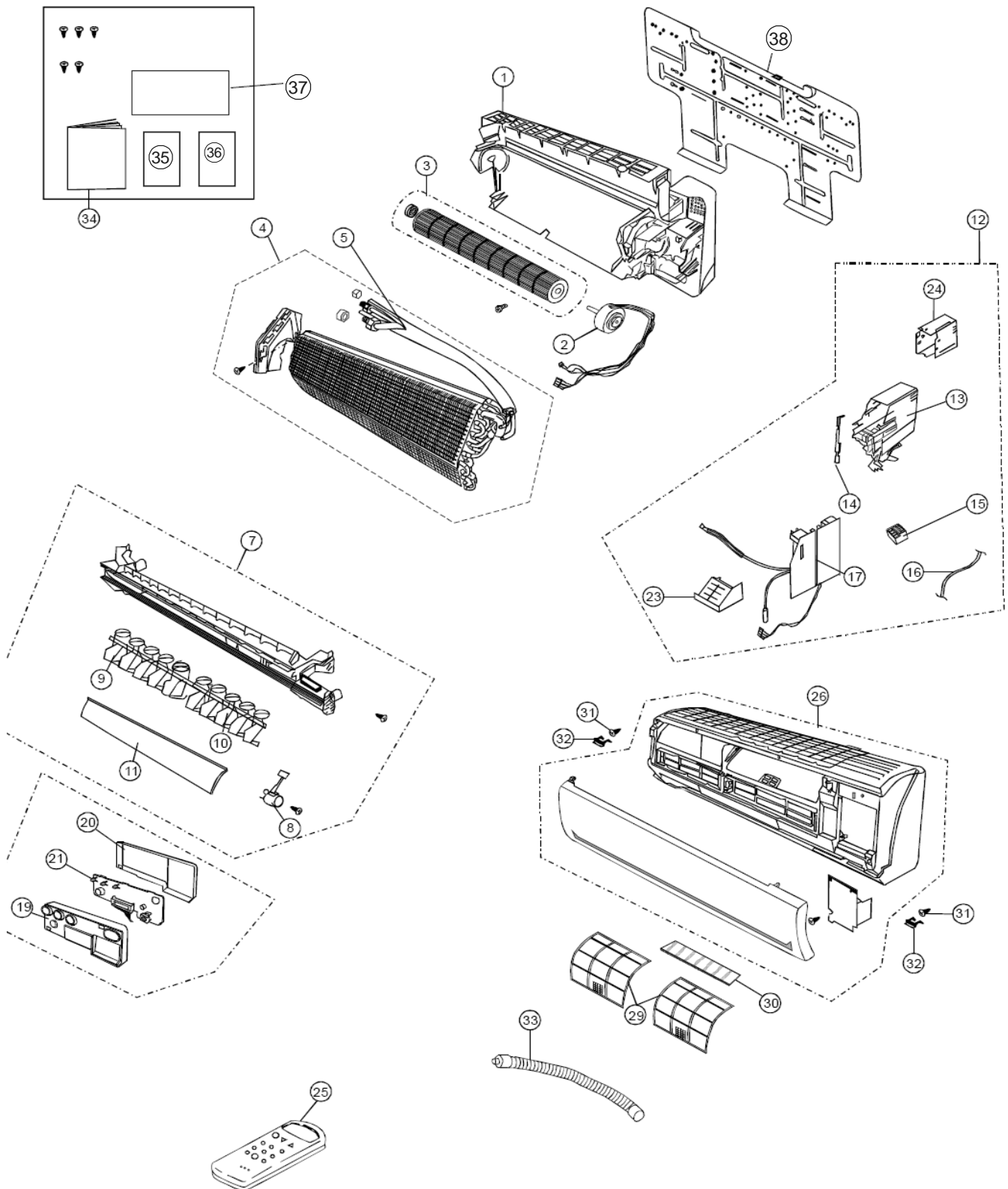

Fig 16

## 16. Exploded View and Replacement Parts List

### 16.1 Indoor Unit



NO	PART NAME&DESCRIPTION	Q'TY	CS-RE9HKE	CS-RE12HKE	RE
1	CHASSIS COMPLETE	1	CWD50C1544	CWD50C1544	
2	FAN MOTOR	1	ARW61M8P30AC	ARW61M8P30AC	
3	CROSS FLOW FAN COMPLETE	1	CWH02C1054	CWH02C1054	
4	EVAPORATOR	1	CWB30C2263	CWB30C2263	
7	DISCHARGE GRILLE COMPLETE	1	CWE20C2731	CWE20C2843	
8	AIR SWING MOTOR	1	CWA981091	CWA981091	
9	HORIZONTAL VANE(LEFT)	1	CWE24C1189	CWE24C1189	
10	HORIZONTAL VANE(RIGHT)	1	CWE24C1190	CWE24C1190	
11	VERTICAL VANE	1	CWE24C1191	CWE24C1191	
12	C-BOX	1	CWH14C6236	CWH14C6237	
13	CONTROL BOARD CASE	1	CWH102337	CWH102337	
14	PARTICULAR PIECE	1	CWD932689	CWD932689	
15	TERMINAL BOARD COMPLETE	1	CWA28C2279	CWA28C2279	
16	POWER SUPPLY CORD COMPLETE	1	CWA20C2680	CWA20C2680	
17	ELECTRONIC CONTROLLER	1	CWA73C3104	CWA73C3105	
19	INDICATOR HOLDER-FRONT	1	CWD932717	CWD932717	
20	INDICATOR HOLDER-BACK	1	CWD932718	CWD932718	
21	INDICATOR PCB	1	CWA745215	CWA745215	
23	CONTROL BOARD FRONT COVER	1	CWH131235J	CWH131235J	
24	CONTROL BOARD TOP COVER	1	CWH131237	CWH131237	
25	REMOTE CONTROL	1	CWA75C3077	CWA75C3077	
26	FRONT GRILLE COMPLETE	1	CWE11C3768	CWE11C3768	
29	AIR FILTER	2	CWD001168	CWD001168	
30	SUPER ALLERU-BUSTER FILTER	1	CWD001202	CWD001202	
31	SCREW-FRONT GRILLE	2	XTT4+16CFJ	XTT4+16CFJ	
32	CAP-FRONT GRILLE	2	CWH521121	CWH521121	
33	DRAIN HOSE	1	CWH851136	CWH851136	
34	OPERATING INSTRUTIONS	1	CWF565951	CWF565951	
35	INSTALLATION INSTRUCTION	1	CWF613429	CWF613429	
36	INSTALLATION INSTRUCTION	1	CWF613430	CWF613430	
37	INSTALLATION INSTRUCTION	1	CWF613431	CWF613431	
38	INSTALLATION PLATE	1	CWH361086	CWH361086	

(Note)

- All parts are supplied from PHAAG, China

## 16.2 Outdoor Unit

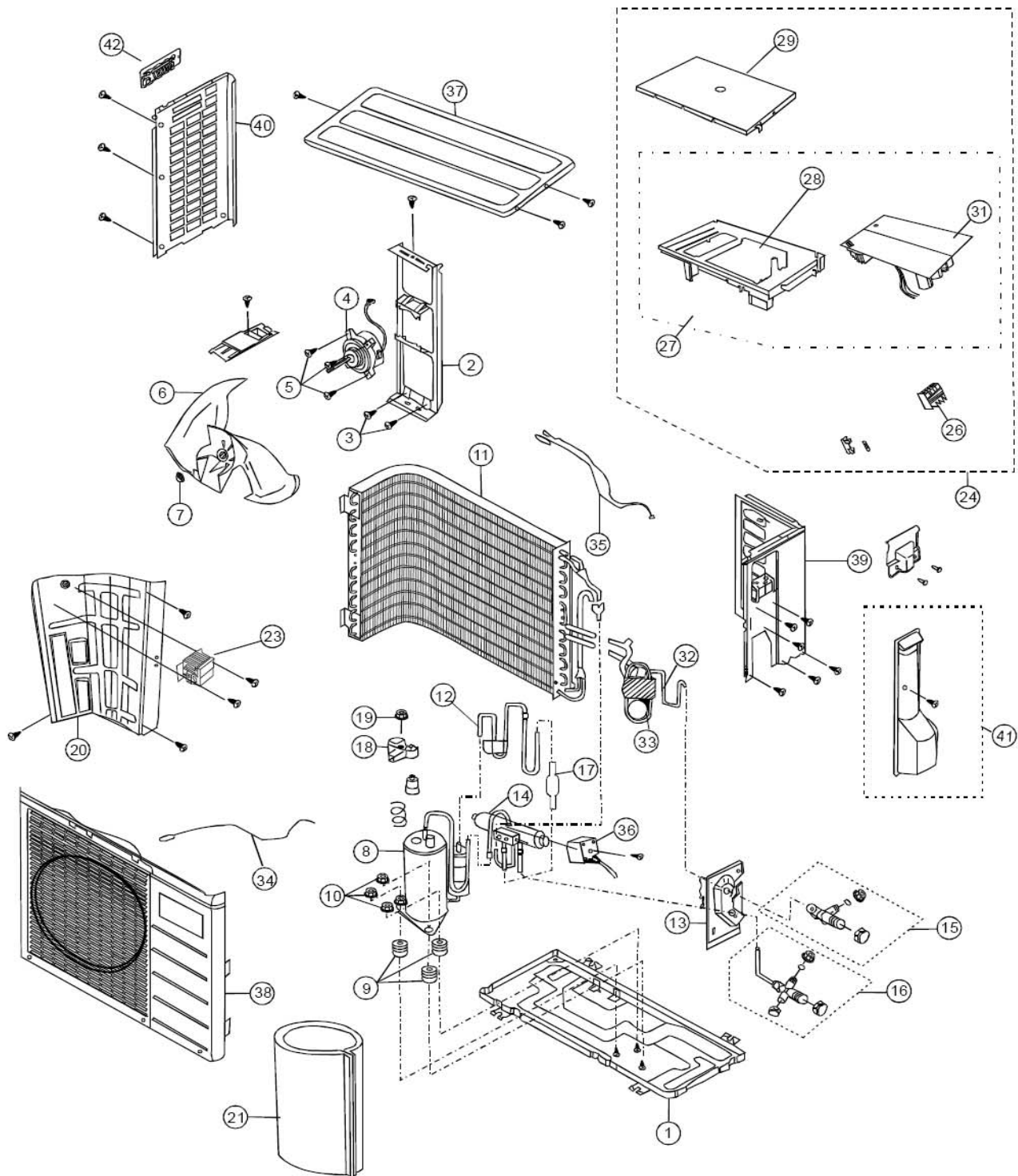

NO	PART NAME&DESCRIPTION	Q'TY	CU-RE9HKE	CU-RE12HKE	RE
1	CHASSIS ASS'Y	1	CWD50K2193A	CWD50K2193A	
2	FAN MOTOR BRACKET	1	CWD541020	CWD541020	
3	SCREW-FAN MOTOR BRACKET	2	CWH551148A	CWH551148A	
4	FAN MOTOR	1	CWA951591	CWA951601	
5	SCREW-FAN MOTOR MOUNT	4	CWH55406J	CWH55406J	
6	PROPELLER FAN ASS'Y	1	CWH03K1034	CWH03K1034	
7	NUT-PROPELLER FAN	1	CWH561036J	CWH561036J	
8	COMPRESSOR	1	CWB092256	CWB092256	
9	ANTI-VIBRATION BUSHING	3	CWH50077	CWH50077	
10	NUT-COMPRESSOR MOUNT	3	CWH56000J	CWH56000J	
11	CONDENSER	1	CWB32C2386	CWB32C2387	
12	TUBE ASSY(3-WAY VALVE)	1	CWT01C4506	CWT01C4507	
13	HOLDER COUPLING ASS'Y	1	CWH351071	CWH351071	
14	4-WAY VALVE	1	CWB001037J	CWB001037J	
15	2-WAY VALVE	1	CWB021251	CWB021251	
16	3-WAY VALVE	1	CWB011308	CWB011308	
17	STRAINER	1	CWB11094	CWB11094	
18	TERMINAL COVER	1	CWH171039	CWH171039	
19	NUT FOR TERMIANL COVER	1	CW7080300J	CW7080300J	
20	SOUND PROOF BOARD	1	CWH151187	CWH151187	
21	SOUND PROOF MATERIAL	1	CWG302433	CWG302433	
23	REACTOR	1	G0C193J00007	G0C193J00007	
24	CONTROL BOX COMPLETE	1	CWH14C6242	CWH14C6243	
26	TERMINAL BOARD ASS'Y	1	CWA28K1185	CWA28K1185	
27	CONTROL BOARD COMPLETE	1	CWH14C6248	CWH14C6249	
28	CONTROL BOARD CASING	1	CWH102298	CWH102298	
29	COVER-CONTROL BOX	1	CWH131300	CWH131300	
31	ELECTRONIC CONTROLLER	1	CWA73C3136	CWA73C3137	
32	TUBE ASS'Y(CAPILLARY)	1	CWT01C3773	CWT01C4021	
33	CAPILLARY	1	CWB15386	CWB15416	
34	SENSOR COMPLETE(COMP)	1	CWA50C2209J	CWA50C2209J	
35	SENSOR COMPLETE(PIPING)	1	CWA50C2521	CWA50C2521	
36	V-COIL COMPLETE	1	CWA43C2261	CWA43C2261	
37	TOP PLATE	1	CWE031084A	CWE031084A	
38	CABINET FRONT PLATE	1	CWE06C1177	CWE06C1177	
39	CABINET SIDE PLATE (R)	1	CWE041301A	CWE041301A	
40	CABINET SIDE PLATE (L)	1	CWE041247A	CWE041247A	
41	CONTROL BOARD COVER	1	CWH13C1161	CWH13C1161	
42	HANDLE	1	CWE161001	CWE161001	

(Note)

- All parts are supplied from PHAAG, China.

Printed in China